



Picture PRP01 Display and Navigation Box

User Guide

Ref No. 148-1-EI-0009 (GB) Version 1



Items Required for Installation:

- + PRP Display
- + Driver board
- + Navigation box
- + Drilling template
- + Hand tools (not provided)
- + Power drill (not provided)
- + Wiring looms

Summary Installation Instructions

Mounting Instructions (Display Panel)

1. Before installation please ensure there is sufficient space on the back of the COP to allow for ventilation for LCD unit.
2. Remove display that is being replaced and make sure area is cleaned and free of dust and dirt.
3. Remove all weld stud mounts that were used for the previous display from the COP.
4. Remove adhesive backing from template and be careful when applying to COP. It is important to ensure that it is placed level and with correct placement for cable clearance.
5. Place drill template over desired area for display placement.
6. Drill four mounting holes at 4.5mm as identified on the template.
7. Remove display from packaging provided. Observe anti-static handling procedures.
8. Remove the driver board from the back of the display taking care when disconnecting the ribbon cable.
9. Remove all nuts and washers provided. Leave the studs fixed to the display frame.
10. From the front of the panel insert the display fixing studs through the drilled holes and fasten in place with washers and nuts provided.

Mounting Instructions (Driver Board)

1. Remove driver board from packaging. Observe anti-static procedures and handle carefully.
2. Peel off protective tape from ribbon cable.
3. Gently lift black protective cover up from over ribbon socket connection.
4. Pay attention to which way up you are inserting the ribbon cable into the connection socket.
5. Slide ribbon cable into socket and gently push lid to lock.
6. Place driver board on mounting studs and secure with washers and nuts (supplied).
7. Mount gong/hall lantern if desired.

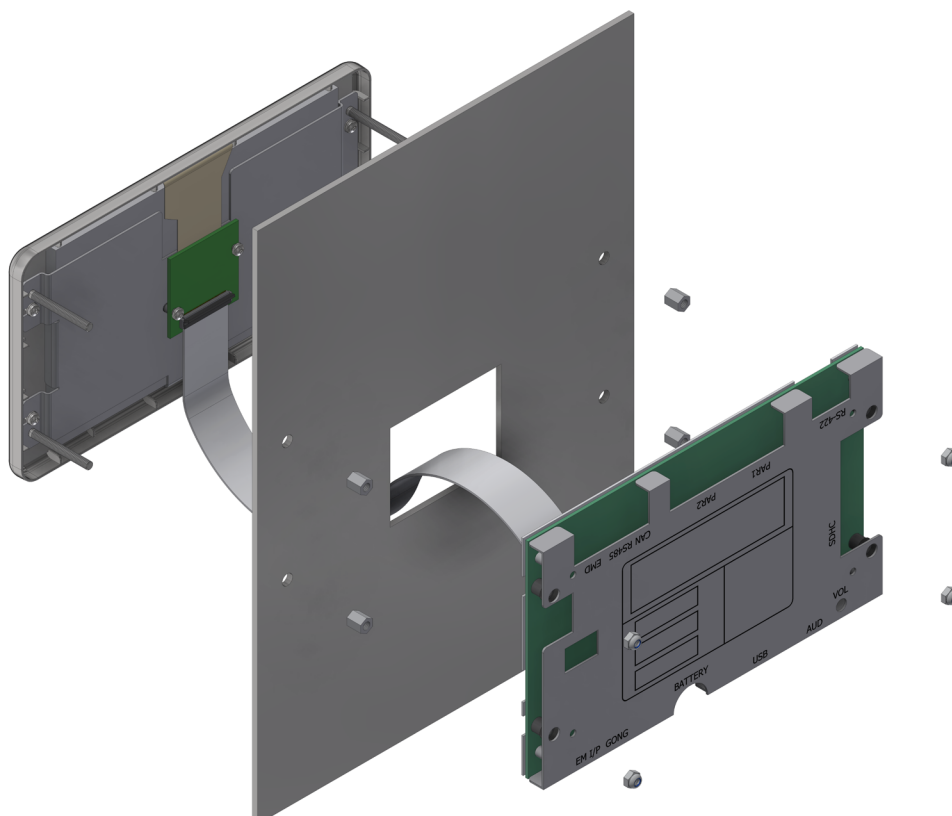

FRONT VIEW

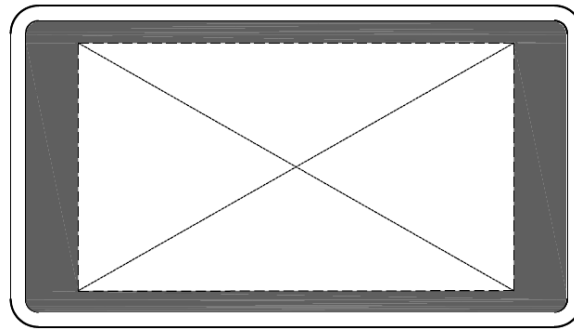

SIDE VIEW

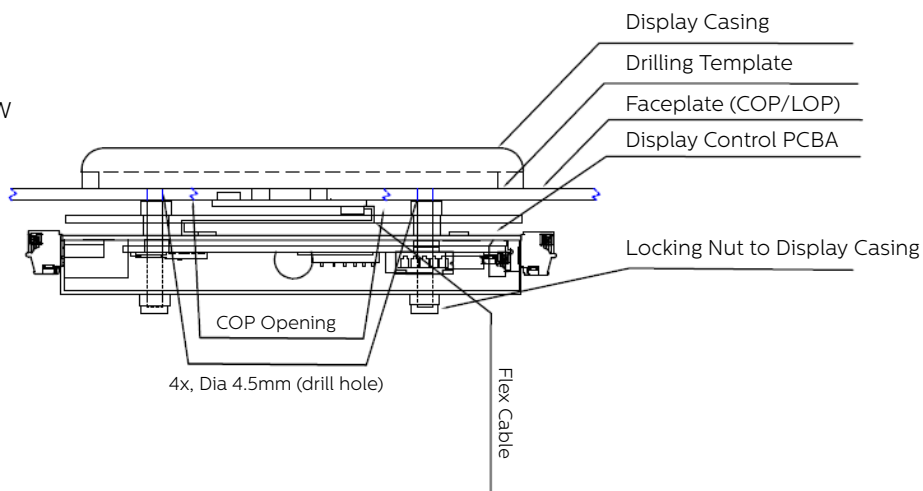

TOP VIEW

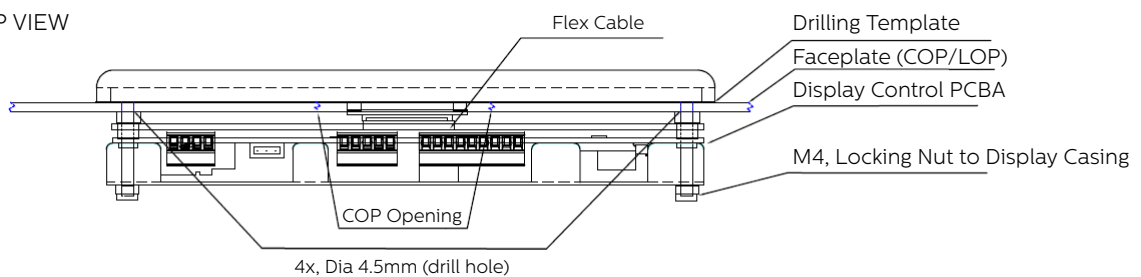

Caution:

- + Risk of electric shock. Never remove the casing of the unit
- + Please take all necessary anti-static precautions before handling equipment
- + Ensure that the Power Supply is connected properly and that the voltage is correct before turning on the System
- + Handle LCD unit with care. Do not knock and place heavy object on top surface of the LCD unit

Wiring Connections - PRP

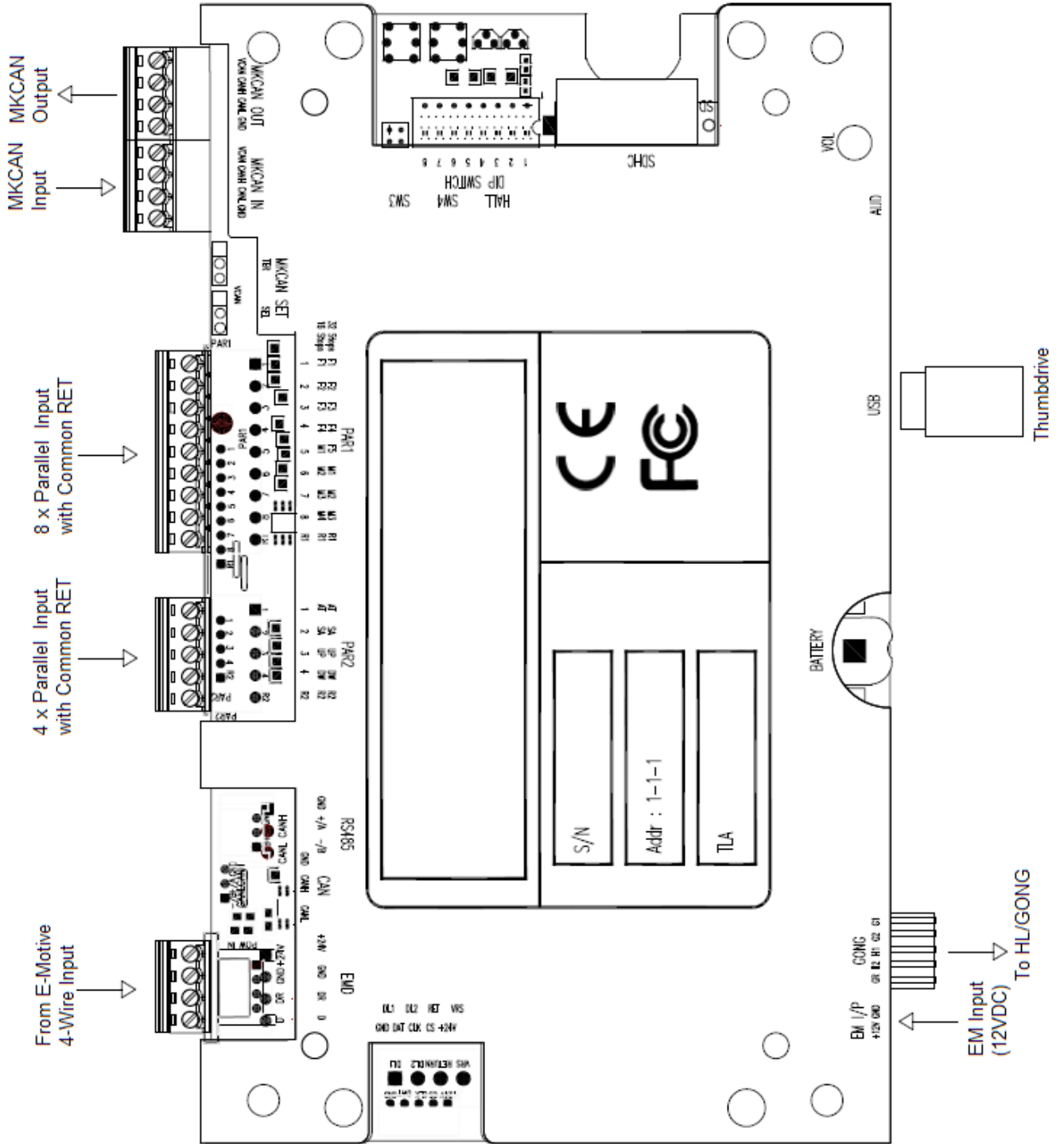

Terminals

Par 1

Terminal	Lift Controller Input	Indication
1	FLOOR NO.	FLOOR POSITION
2	FLOOR NO.	FLOOR POSITION
3	FLOOR NO.	FLOOR POSITION
4	FLOOR NO.	FLOOR POSITION
5	LIFT MESSAGE	OVERLOAD
6	LIFT MESSAGE	FIRE SERVICE
7	LIFT MESSAGE	OUT OF SERVICE
7	LIFT MESSAGE	PREFERENCE
RI	Link to OVDC	Link to OVDC

Par 2

Terminal	Lift Controller Input	Indication
1	*NOT USED*	*NOT USED*
2	SCROLL ARROW	
3	UP ARROW	UP ARROW
4	DOWN ARROW	DOWN ARROW
R2	Link to OVDC	Link to OVDC

Truth Table

PAR1		Truth Table		Binary1
BIT 1	BIT 2	BIT 3	BIT 4	FLOOR O/P
0	0	0	0	BLANK
1	0	0	0	0
0	1	0	0	1
1	1	0	0	2
0	0	1	0	3
1	0	1	0	4
0	1	1	0	5
1	1	1	0	6
0	0	0	1	7
1	0	0	1	8
0	1	0	1	9
1	1	0	1	10
0	0	1	1	11
1	0	1	1	12
0	1	1	1	13
1	1	1	1	14

Mounting Instructions (Navigation Box)

1. Mount the Navigation box on top of elevator car
2. Fasten Navigation box to position using mounting holes
3. Wire the Navigation box to the relevant devices e.g. E-Motive PRP paying particular attention to polarity of power and CANBus connections of each of the devices.
4. Ensure cabling is run securely away from any moving devices and sharp edges.

Powering On and Setup (PRP and Navigation Box)

1. Plug power socket into driver board of PRP.
2. Power up the system.
3. The screen and Navigation box LED's should become active. Refer to tri-colour LED operation for further detail.
4. Enter the onboard programming for the display via the tact switches or hall effect sensor.
5. Configure your display where appropriate (see onboard programming for further details).
6. Enter the Navigation box into Nav learn mode (see Nav Learn mode for further details).
7. Once in Nav learn mode, follow the on-screen instructions to complete the Nav learn function.
8. Allow the elevator to stop at every level. Do not proceed to next level until indicator advises "stop learned".
9. Once a trip has been completed to the top of the elevator shaft, replicate that trip going down to the bottom stopping at every floor.
10. The Display will then re-boot and floor level information will be displayed.

MK-CANbus Setup:

You must ensure that if your PRP is correctly configured dependent on its position along the CANbus. Transparent or first/last operator. This is done using the jumper switches SEL and TER.

SEL - By default, this is set to Pin 1 and 2 ("ON")

TER - By default, this is set to Pin 2 and 3. Set to Pin 1 and 2 if it is the first or last device on bus line.

Wiring Connections – Navigation Box

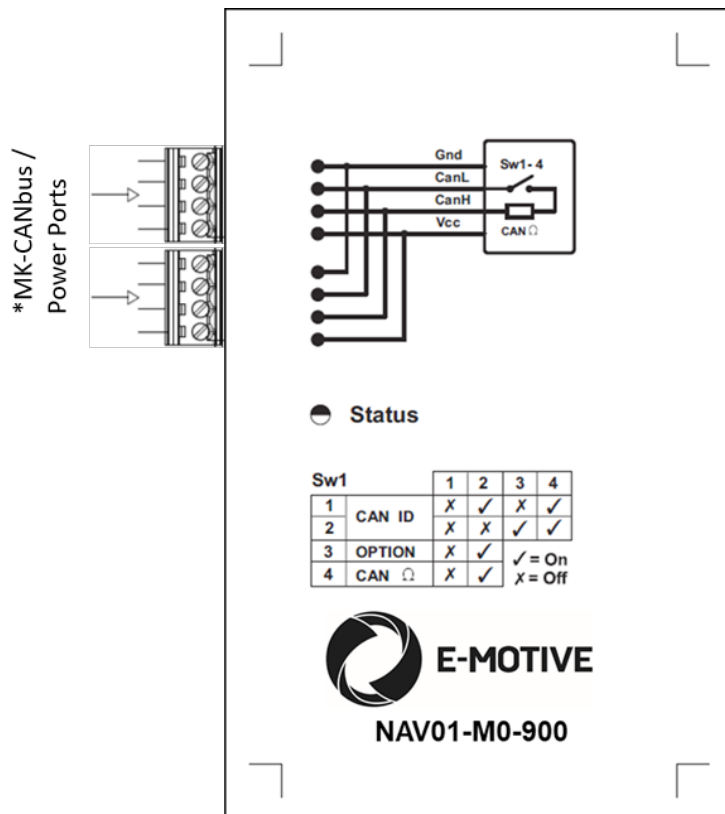

*Either port can be used to power the Navigation Box or can be used as a bridging port to other MK CANBus enabled product.

Power

E-Motive PRP runs of either a 24v or 12v power supply to the Navigation box via a 4-pin connector through which it receives the power and connects to the can bus. The power voltage can go from 10 to 30 volts dc.

Setup

- + Switches 1 and 2 are used for elevator shaft address selection. This allows you to select the shaft where the device is placed. From 1 to 4*.
- + Switch 3 enables manual initiation of Nav learning mode without a display (this function is not recommended).
- + Switch 4 controls the MK CANbus termination resistor.

*Important - Shaft number must correspond to the other items connected along the MKCANbus e.g. PSP, PRP, DCP, DAU etc. Ensure this is the same as your display.

Sw1		1	2	3	4
1	CAN ID	X	✓	X	✓
2		X	X	✓	✓
3	OPTION	X	✓	✓ = On	
4	CAN Ω	X	✓	X = Off	

Tri-Colour LED Operation – Navigation Box

Once power is available, the Navigation box will show its status via the tri-colour led. The following table describes their meaning:

	Function	Colour	Frequency
Initialisation / Operation / Nav Learn	Initialising Sensor	Red	Fast
	Navigation Missing State	Red	Slow
	Navigation Operating (Elevator Moving)	Green	Fast
	Navigation Operating (Elevator Stopped)	Green	Slow
	Nav Learn (Elevator Moving)	Orange	Fast
	Nav Learn (Elevator Stopped)	Orange	Slow
Firmware Update	Power On	Red-Orange-Green	x 1
	Update Starting	Orange	Constant
	Update Complete	Green	x 3
	Update Error	Red	x 3
	Ready	Green	Constant
	No Firmware Present	Red	Slow

Tri-Colour LED Sequences Definitions

Initialising Sensor – Waiting for application code to run and enabling sensors

Navigation Missing State – Navigation box has not undergone Nav learn mode to configure floor levels. Enter Nav learn mode via your display to configure.

Navigation Operating (Elevator Moving) – Device is configured and recognises elevator is moving

Navigation Operating (Elevator Stopped) – Device is configured and recognises elevator has stopped

Nav Learn (Elevator Moving) – Device is in Nav learn mode and recognises elevator is moving

Nav Learn (Elevator Stopped) – Device is in Nav learn mode and recognises elevator is stopped

Power On – Device has been powered on and is initialising

Update Starting – Firmware update is available and has begun

Update Complete – Firmware update is complete

Update Error – Firmware updated has failed, please try again and if error persists contact the Avire help desk

Ready – Device is up to date and therefore no update is available. The Nav box will then enter regular operation

No Firmware Present – There is no firmware available on the device, please contact the Avire helpdesk.

Nav Learn – Floor Learning mode

The following sequence depicts the steps needed to configure the Navigation Box to your installation:

1. Enter the onboard programming function either via the tact switches or hall effect sensor
2. Enter Nav learn mode. When entered the following pictogram will be represented on the display.
3. A 40 second countdown will begin allowing time for you to ensure the elevator is on the bottom position of the elevator shaft

STOPS LEARNING

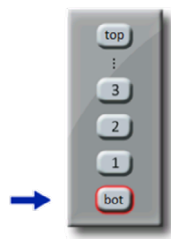

Press button to bring car to bottom floor.
Waiting for car to be at bottom before we start learning.



Waiting to start...

4. Once the 40 second countdown is complete the below pictogram will show prompting the installer to press every floor button available on the COP

STOPS LEARNING

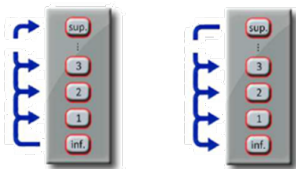

From the bottom floor, press all stop buttons going up to the top floor to stop at every floor.

Then from the top floor, press all stop buttons on way down to the bottom floor to stop at every floor.

Learning

5. Your elevator should now be travelling to each stop available. Once a stop has been reached the display will show this sequence “Learning Stop X” > “Stay on this stop” > “Stop Learned” and will continue for however many stops are available
6. Once the top floor has been reached, select every floor again for the travel down to the bottom of the elevator shaft.
7. On each floor stoppage the display will indicate the following sequence “Confirming Stop X” > “Stay on this stop” > “Stop confirmed”
8. Once complete the display will then reboot and if successful show floor position

If Nav learn is unsuccessful retry the process. If issues persist, please contact our technical support team.

Operation of Programming Tool in PSP/PRP

Entering the On-Board Programming Menu

This guide describes the operation of the on-board programming tool available on PSP and PRP.

The on-screen display (OSD) menu can be activated either by the tact switches [SW3 and SW4] found at the back of the PSP/PRP display or by the magnet activator provided in the package.

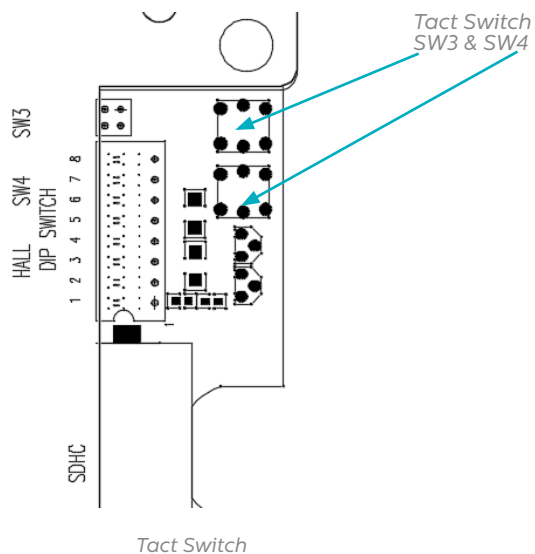

Magnet Activator*

**The magnet activator is useful in programming the PSP/PRP display if the display is installed or if the tact switches are not easily accessible.*

The maximum distance should not exceed 30mm from the left short edge of the display and the material where the display is mounted should not consist of any ferromagnetic material to prevent obstruction.

Tact Switch On-Board Control

To activate the OSD menu, press both SW3 and SW4 at the same time.

Magnet On-Board Control

To access the OSD menu when using the magnet activator:

1. Swipe the magnet clockwise once against the COP in a semi-circular motion from the bottom up as illustrated below.

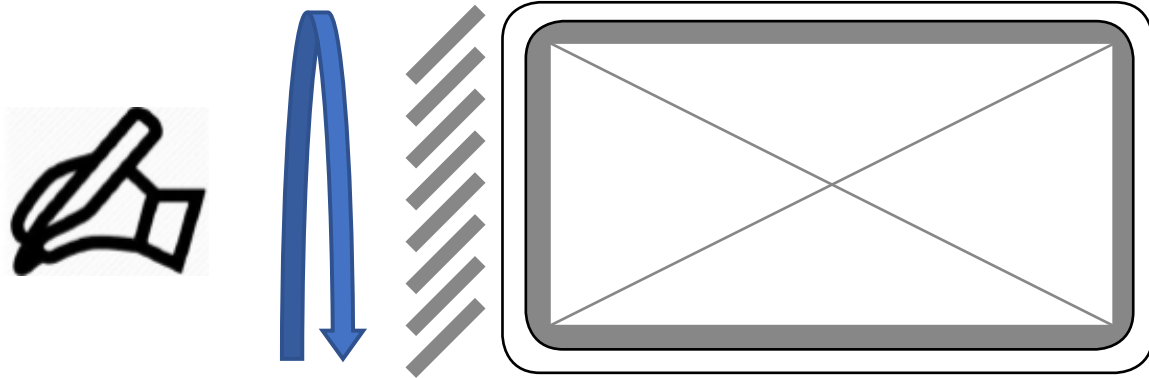

2. Move the magnet activator away from the swiping area.

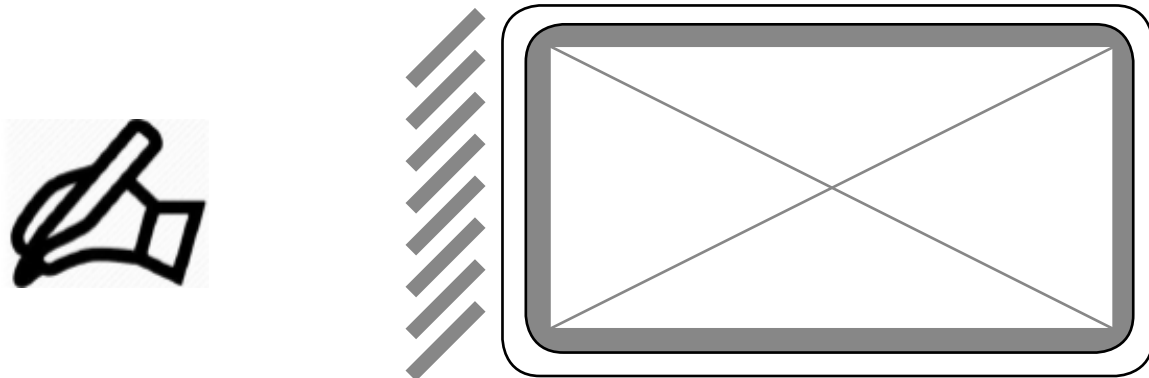

3. Next, move it in a semicircle from the top in an anti-clockwise direction to activate the OSD menu.

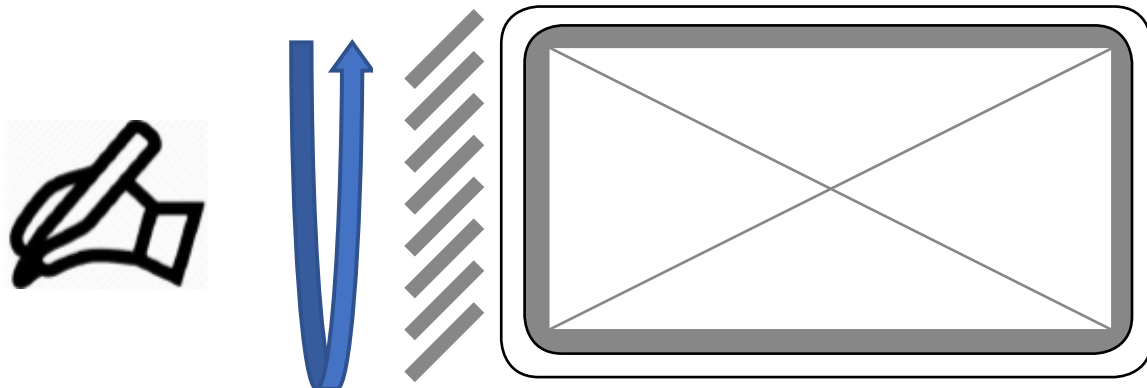

Configuring your display

Once activated the OSD menu will appear in a blue box as illustrated below.

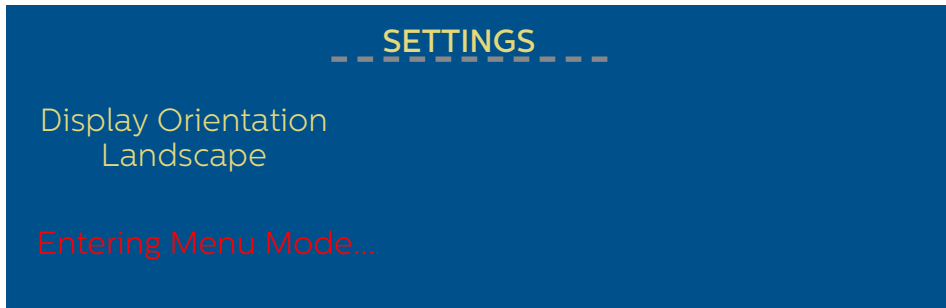

The respective fields can then be set after the “Entering Menu Mode...” disappears.

Once the OSD menu is active, you can navigate the menu via tact switch by pressing:

SW3 for mode select.

SW4 for item select.

Or via magnet by:



Up stroke for mode select



Down stroke for item select

1. “Display Orientation” – Set the orientation of the PSP/PRP display

Landscape or Portrait.

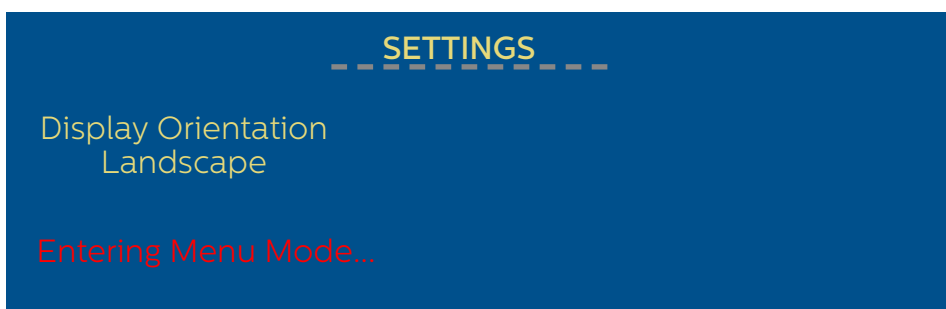

2. “Lift Information Input Type – Serial” – Set the serial interface

- MKCAN or
- Emotive 4-Wire

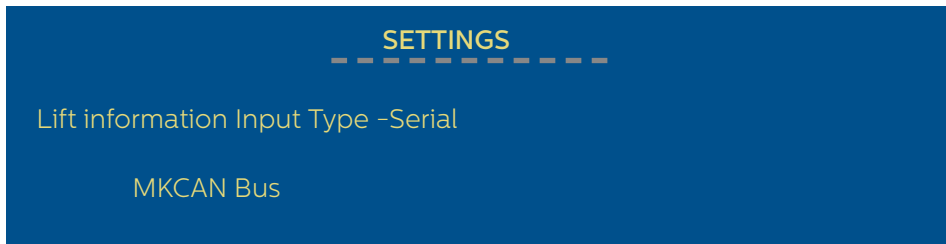

3. “Lift Information Input Type – Parallel (Discrete)” – Set the parallel interface

- Binary 1 (Starts from 1)
- Binary 0 (Starts from 0)
- Grey 1 (Starts from 1)
- Grey 0 (Starts from 0)
- Single Wire Per Floor

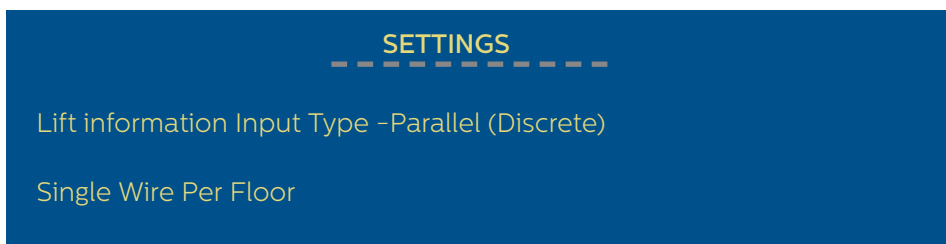

4. “MKCAN Group ID” – Set the ID from 1 to 4 This refers to the assigned lift.

**Important - Shaft number needs to correspond to the other items connected along the MKCANbus e.g. PSP, PRP, DCP, DAU etc. ensure this corresponds to the Navigation box settings*

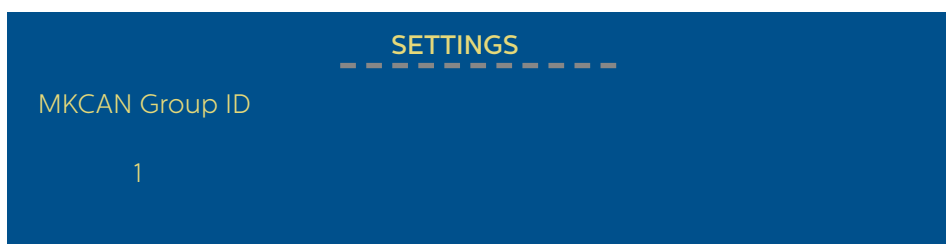

5. “MKCAN Ext Address” – Set the extended address from 0 to 62 is for main car display, 001 – 062 can be set for additional displays or audio points.



6. “To Start Navigator Learning” – Required if the serial interface is set to MKCAN and the PSP/PRP display needs to be configured with the Navigation Box (MK817) for the first time before use

- Skip – Select this if it is not required to be configured
- Traction – Select this if configuring for Traction lift
- Hydraulic – Select this if configuring for Hydraulic lift
- Not Applicable – If serial interface is not selected as MKCAN

* Make sure that MK817 is connected to the PSP/PRP

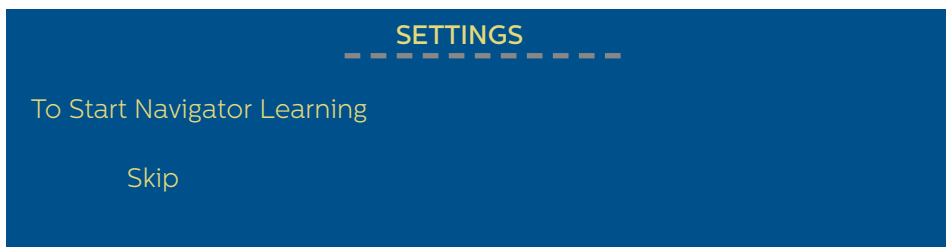

7. “Power Save” – Set the status of the power save mode

- ON – Car unit will go black and Landing unit will dim either after 5 minutes of no arrow activity or if received the power save command from E-Motive 4-Wire interface
- OFF – Power Save mode will be disabled

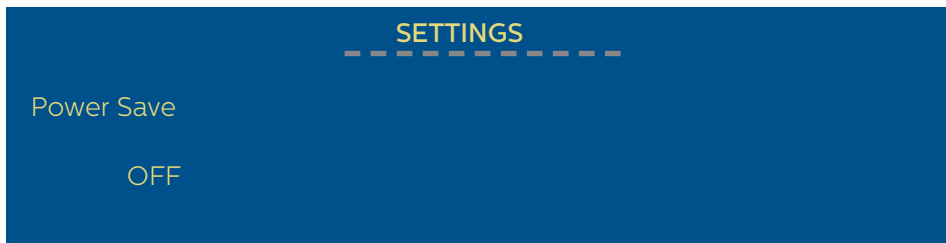

8. “Landing Address” – Set the Landing Address from 0 to 32 where 0 is for Car unit and 1 to 32 is for Landing unit.



9. “Maximum Number of floors (Floor Bit)” – Set the maximum number of floor numbers

- 16 floors (4-bit)
- 32 floors (5-bit)

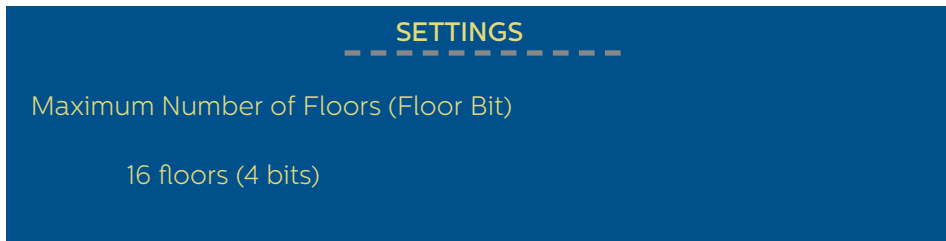

10. “Floor Legends” – Set the floor legends from 0-9, - (Hyphen), . (Full stop), B, G, M, P and Space.



To edit the floor legend, press SW4 or stroke down to set to “Edit” mode.

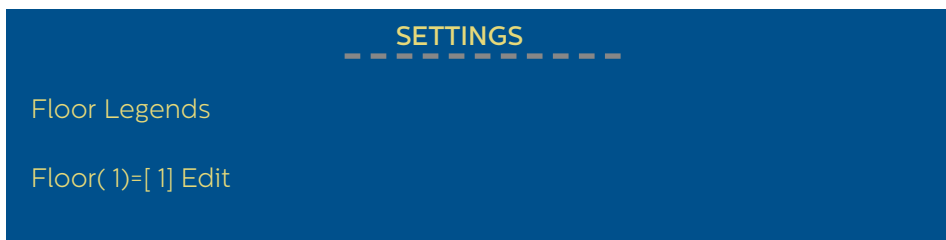

Press SW3 or stroke up to edit the floor legends, starting from the leftmost digit.

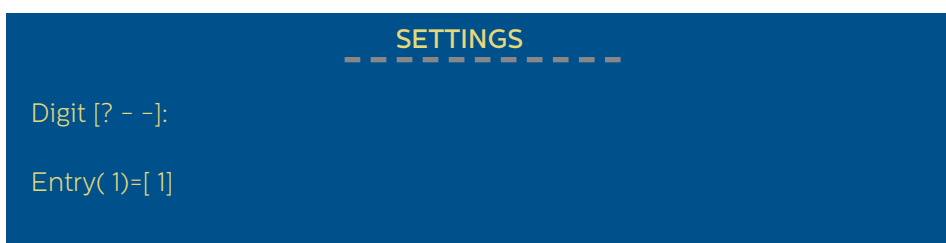

Press SW4 or stroke down to select the value of the selected digit from 0-9, - (Hyphen), . (Full stop), B, G, M, P and Space.

Press SW3 or stroke up to continue to the next digit until the 3 digits are set.

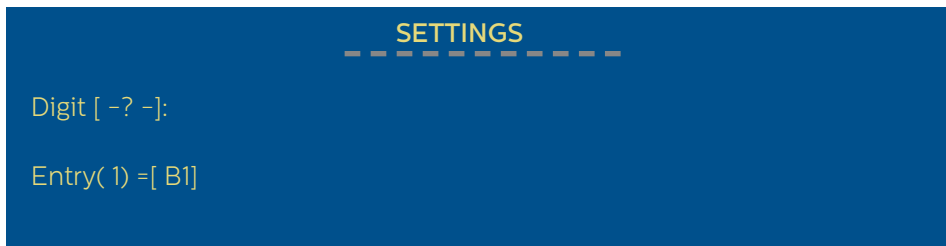

Press SW3 or stroke up to edit the next floor entry.



Press SW4 or stroke down to change to “Skip” mode if the next floor entry is not required to change.

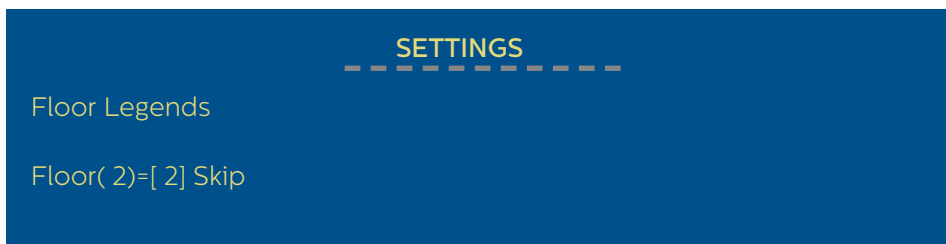

Continue the process for the rest of the floor entries.

11. “Arrow” – Set the status of the arrow

- Yes, with Scroll
- Yes, without Scroll
- No Arrow

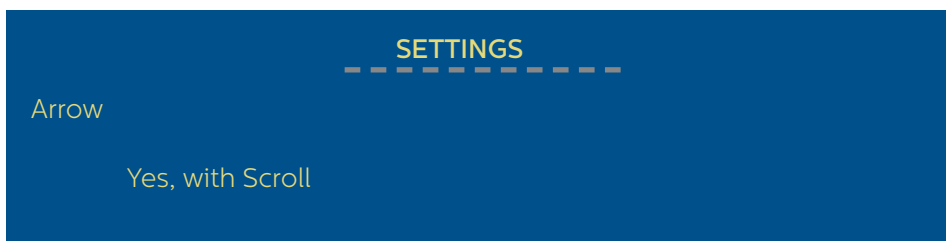

12. “Status Message” – Select the message content to

- OVERLOADED
- LIFT OVERLOADED
- FIRE SERVICE
- FIRE RECALL
- MAINTENANCE
- PREFERENCE
- EXCLUSIVE
- OUT OF SERVICE
- PRIORITY SERVICE
- FIRE ALARM

The number of messages available would be dependent of the number of floor bits that have been assigned previously.

4 floor bits – 4 messages

5 floor bits – 3 messages

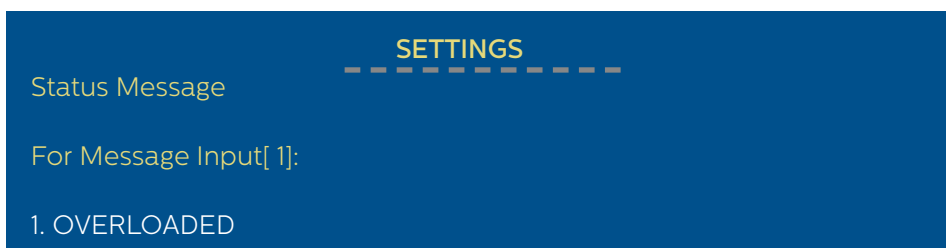

13. “Background Colour” – Set the background colour to blue/navy/green/red/yellow/white/black/light grey

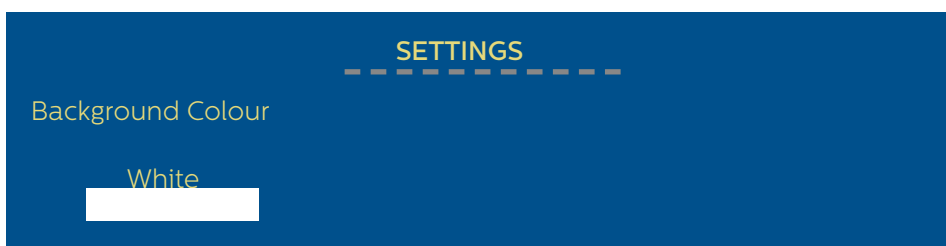

14. “Floor Text Colour” – Set the floor text colour to blue/navy/green/red/yellow/white/black/light grey

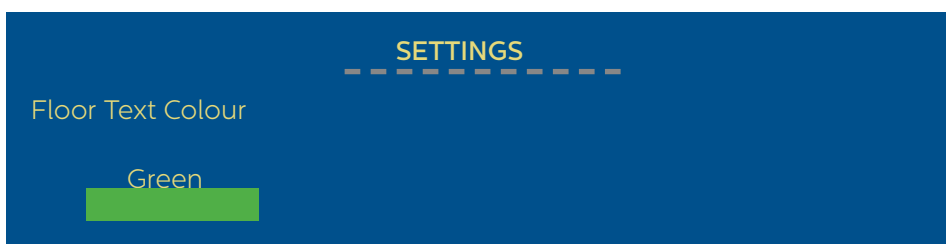

15. “Lift Message Colour” – Set the floor text colour to blue/navy/green/red/yellow/white/black/light grey

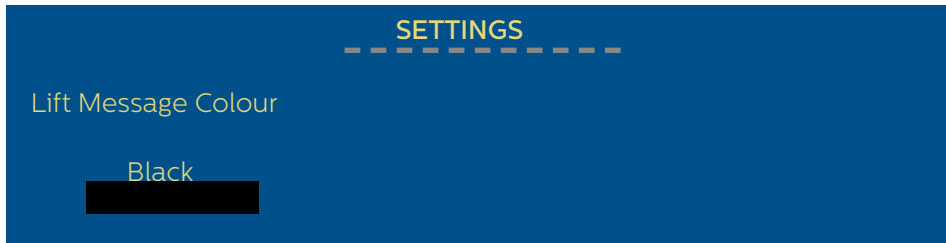

16. “Lift Message Background Colour” – Set the background colour of the lift message to blue/navy/green/red/yellow/white/black/light grey

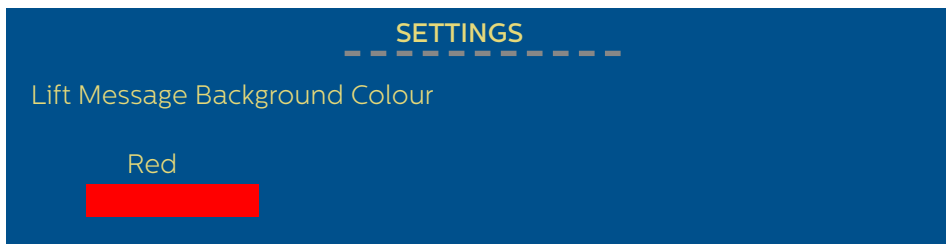

17. “Arrow Style” – Select 1 of the 2 arrow styles that is pre-installed in the layout.
• Style-1 – Black Colour
• Style-2 – White Colour

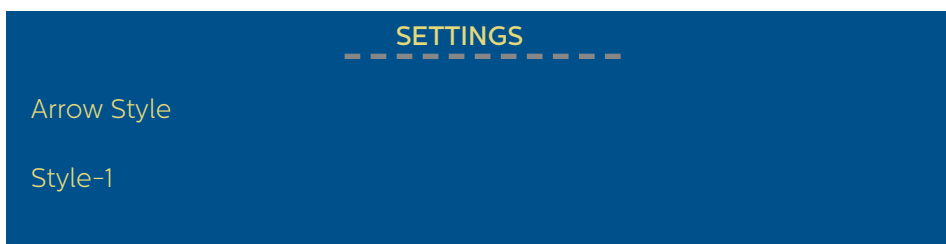

18. The PSP/PRP is now easily configured with the use of the programming tool. The display will now reboot and load the configured changes.

Overview of On-board Programming Tool

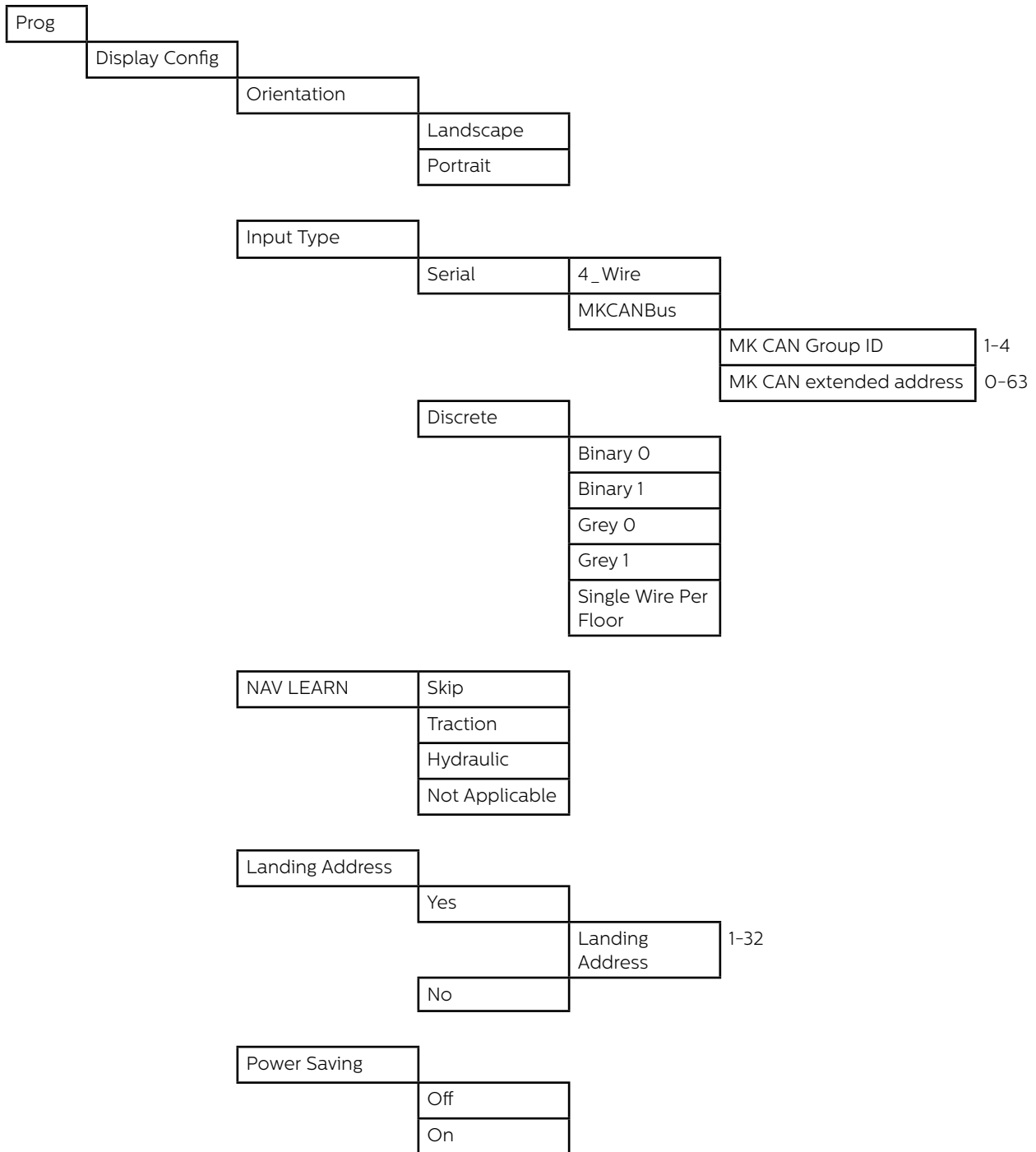

Floor Info	Maximum Number of Floors	4-Bit (16 floors)	
		5-Bit (32 floors)	
Floor Legends	Floor 1		Numbers, Letters and Characters
	Floor 2		Numbers, Letters and Characters
	Floor 3		Numbers, Letters and Characters
Arrow	Yes, with scroll		
	Yes, without scroll		
	No Arrow		
Status Msg	Yes	Msg1	1. OVERLOADED 2. LIFT OVERLOADED 3. FIRE SERVICE 4. FIRE RECALL 5. MAINTENANCE 6. PREFERENCE 7. EXCLUSIVE 8. OUT OF SERVICE 9. PRIORITY SERVICE 10. FIRE ALARM
		Msg 2	as above
		Msg 3	as above
		Msg 4	as above
	No		

Appearance	
	Background Colour
	Blue
	Navy
	Green
	Red
	Yellow
	White
	Black
	Light Grey

Floor Text Colour	
	Blue
	Navy
	Green
	Red
	Yellow
	White
	Black
	Light Grey

Lift Message Colour	
	Blue
	Navy
	Green
	Red
	Yellow
	White
	Black
	Light Grey

Lift Message Background Colour	Blue
	Navy
	Green
	Red
	Yellow
	White
	Black
	Light Grey

Arrow Style	Style 1 (Black Colour)
	Style 2 (White Colour)

