

# Installation & Operations Manual

Public Safety Distributed Antenna Systems

---

**SAFE-1020:** Fiber DAS Head End

**SAFE-1015:** Fiber Remote Unit  
(Used With SAFE-1020)

**SAFE-1030:** Bi-directional Amplifier (Coax)

**SAFE-BBU-1000:** Backup Battery Unit

**SAFE-AN-1002:** Remote Annunciator



## Warning: This is not a consumer device.

It is designed for installation by FCC LICENSEES and QUALIFIED INSTALLERS. You MUST have an FCC LICENSE or express consent of an FCC licensee to operate this device.

You MUST register Class A signal boosters (as defined in 47 CFR 90.219) online at:  
<http://www.fcc.gov/signal-boosters/registration>

Unauthorized use may result in significant forfeiture penalties, including penalties in excess of \$100,000 for each continuing violation. This device complies with part 15 of the FCC Rules.

Operation is subject to the following two conditions:

1. This device may not cause harmful interference, and
2. This device must accept any interference received, including interference that may cause undesired operation.

## Warning: Laser output from fiber ports on SAFE-1020 Head-end

**Do not stare into fiber connectors or permanent eye damage may occur.**

- Laser output from the green SC/APC connectors.
- The system uses a Class 3R laser diode.

The fiber used for the SAFE-1020 Fiber DAS is an industry-standard single mode fiber (9/125um). The connectors used are industry standard SC/APC (typically green colored). Maximum optical loss between head-end and remote is 5dB optical

### Liability Disclaimer:

The information contained in this document is assumed to be correct and current. The manufacturer is not responsible for errors or omissions and reserves the right to change specifications at any time without notice. RATH® by AVIRE assumes no responsibility for its use nor for any indirect, incidental damage or loss resulting from its use.

### FCC Antenna Requirements

The user must ensure that the installation meets FCC RF exposure limits. The minimum distance between any person and the operating antenna must be 14 inches or 35 centimeters. The antenna must be mounted on a stable, permanent structure. Maximum effective radiated power (ERP) is five (5) watts per FCC regulations per rule part 90.219(e)(1). The FCC licensed and qualified installer must calculate the total transmitted power, taking into account the losses of the cables and splitters, etc., plus the gain of the antenna to assure compliance with the maximum exposure regulation. Lightning protection is required on all antennas. Loss or damage as a result of lightning is not covered by the warranty. Antennas must be connected prior to turning on power to the unit.

### **Under Industry Canada Regulations:**

This radio frequency power amplifier may only be used with the transmitter with which the amplifier has been certified by Industry Canada. The certification number for the transmitter with which this amplifier is permitted to operate is IC:22303 Under Industry Canada regulations, this radio transmitter may only operate using an antenna of a type and maximum (or lesser) gain approved for the transmitter by Industry Canada. To reduce potential radio interference to other users, the antenna type and its gain should be so chosen that the equivalent isotropically radiated power (e.i.r.p.) is not more than that necessary for successful communication. This radio transmitter (identify the device by certification number, or model number if Category II) has been approved by Industry Canada to operate with the antenna types listed below with the maximum permissible gain and required antenna impedance for each antenna type indicated. Antenna types not included in this list, having a gain greater than the maximum gain indicated for that type, are strictly prohibited for use with this device.

Conformément à la réglementation d'Industrie Canada, le présent amplificateur de puissance radiofréquence peut être utilisé seulement avec un émetteur avec lequel il a été certifié par Industrie Canada. Le numéro d'identification d'Industrie Canada pour l'émetteur avec lequel l'amplificateur est autorisé à fonctionner est IC : 22303 Conformément à la réglementation d'Industrie Canada, le présent émetteur radio peut fonctionner avec une antenne d'un type et d'un gain maximal (ou inférieur) approuvé pour l'émetteur par Industrie Canada. Dans le but de réduire les risques de brouillage radioélectrique à l'intention des autres utilisateurs, il faut choisir le type d'antenne et son gain de sorte que la puissance isotrope rayonnée équivalente (p.i.r.e.) ne dépasse pas l'intensité nécessaire à l'établissement d'une communication satisfaisante. Le présent émetteur radio (identify the device by certification number, or model number if Category II) a été approuvé par Industrie Canada pour fonctionner avec les types d'antenne énumérés ci-dessous et ayant un gain admissible maximal et l'impédance requise pour chaque type d'antenne. Les types d'antenne non inclus dans cette liste, ou dont le gain est supérieur au gain maximal indiqué, sont strictement interdits pour l'exploitation de l'émetteur.

# Table of Contents

<b>Section 1: System Specifications</b> .....	Page 06
<b>Section 2: Operational Overview</b> .....	Page 09
Theory of Operation .....	Page 09
System Topology, Block Diagrams .....	Page 10
<b>Section 3: Inside Your Enclosure</b> .....	Page 14
Front (Control) Panel .....	Page 15
Modular Card System (Channel Cards) .....	Page 16
<b>Section 4: Enclosure Installation</b> .....	Page 17
<b>Section 5: Electrical Wiring and Components</b> .....	Page 18
<b>Section 6: Battery Backup Unit (BBU) Installation and Connection</b> .....	Page 19
<b>Section 7: System Alarms Overview and Connection</b> .....	Page 21
<b>Section 8: Power Up Your System</b> .....	Page 24
<b>Section 9: Alarm Testing</b> .....	Page 25
<b>Section 10: Installing the NMS Software</b> .....	Page 26
<b>Section 11: Connecting the BDA or Fiber DAS Units to the NMS</b> .....	Page 27
Connecting a SAFE-1030 BDA .....	Page 28
Connecting a SAFE-1020/SAFE-1015 Fiber DAS .....	Page 29
Verifying Connection .....	Page 30
<b>Section 12: System Operation (Notifications &amp; Alarms)</b> .....	Page 31
LED Notifications .....	Page 31
Silencing Audible Alarms .....	Page 31

The following specifications are the same for both the Fiber DAS system featuring the SAFE-1020 head end and the Passive DAS SAFE-1030 BDA unless otherwise identified. For detailed specification tables, please refer to the system data sheets.

## Components

The minimum subassemblies necessary to form a viable system (“control unit”) are:

- One BDA/head-end
- Remote units (for a fiber system only)
- One BBU with LiFePO4 battery pack  
(includes three 105-amp hour cells for a total of 1008 watt-hours)

## Frequency Bands of Operation

The authorized operating bands for the public safety distributed antenna systems include:

- VHF: 138 – 174 MHz
- UHF: 380 – 512 MHz
- FirstNet: 758 – 768 MHz to 788-789 MHz
- 700 band: 763 – 775 MHz and 793 – 805 MHz (uplinks & downlinks)
- 800 band: 806 – 824 MHz and 851 – 869 MHz (uplinks & downlinks)
- 900 band: 896 – 941 MHz



## RF Output

The plug-in channelizer cards and the electronic tuning via the Network Management System (NMS) determine the frequency retransmitted. The manufacturer sets the general operating bands for each plug-in card; each card can accommodate frequencies only within their designated band. The operating bands cannot be modified by the user. Only the channelized frequency operating within the band can be user modified.

The RF output is controlled automatically by an Automatic Level Control (ALC) circuit within the cards. The user cannot set the output power to exceed FCC limits; however, the user can set the output power lower than the designed maximum using the NMS to prevent feedback oscillations (if desired).

## RF Input

- The maximum RF input to any port is -10dBm for linear performance.
- The maximum RF input to prevent damage is 0dBm.
- Levels above 0 dBm may damage the unit permanently.

## System Power

Public safety distributed antenna systems can be ordered with either DC (default) or AC input power options.

- **12 VDC Power Option:** The system operates from +9 to +12 VDC (12A max). Typically, this would be provided by a separate Battery Backup Unit (model SAFE-BBU) which reliably delivers +12 VDC to the BDA.
- **120/220 VAC Power Option:** The system operates from either 120 or 220 VAC (2A max). This requires three connections: Live, Neutral and Ground. Earth grounding the NEMA case is required, and a terminal strip is provided within the unit for this purpose.

**Note:** Follow all local code requirements.

## Backup Battery Unit

- BBU Voltage Range: 110 to 120VAC
- AC Frequency: 50 to 60 Hz
- Maximum Current: 2 amps
- AC Power Input: Located inside Battery Backup Unit (BBU), lower left 3 terminal positions (line, neutral, ground)
- Rechargeable Batteries: 10.95Vmax, 12A max, 2K amp hours max, LiFePO4 battery, 12 hour minimum, 24-hour maximum standby operating time

## Electrical Grounding

The BDA enclosures are grounded to the electrical ground terminals internally. The user must ensure that the earth ground connection at the terminal strip or the grounding lug on the outside of the enclosure is properly connected to the external earth ground.

## Power Consumption

Power consumption is directly related to the number of channels or bands engaged, and therefore, the number of plug-in cards integrated into the system. The system has a dedicated card per band or frequency (in the case of Class A); when a channel is not keyed up, its internal power control circuitry reduces its power consumption to the minimum level.

Typical power consumption ranges from 25 to 65 watts for a single BDA unit. The RATH® by AVIRE applications engineering team will determine and provide the exact power consumption of your unit, which is used to determine the backup battery needed to fulfill 12 or 24-hour requirement.

## Specification Summary

	<b>Fiber DAS SAFE-1020 / SAFE-1015</b>	<b>Passive DAS SAFE-1030</b>
<b>Power Supply</b>	9 VDC to 12 VDC, DC provided by battery backup unit	9 VDC to 12 VDC, DC provided by battery backup unit
<b>Power Consumption</b>	40 watts (avg)/80 watts (max peak)	40 watts (avg)/1000 watts (max peak)
<b>Output Power Per Band</b>	700 & 800 MHz: 30 dBm (+/-2 dB) UHF: 28 dBm (+/-2 dB) VHF: 27 dBm (+/- 2 dB)	700 & 800 MHz: 30 dBm (+/-2 dB) UHF: 28 dBm (+/-2 dB) VHF: 27 dBm (+/- 2 dB)
<b>RF Input</b>	-10 dBm (max, no damage)	-10 dBm (max, no damage)
<b>RF Output</b>	0.5 to 3 watts	1 watt (2 watts with dual band)
<b>Noise Figure</b>	6 dB to 8 dB (typical)	5 dB to 8 dB (typical)
<b>Gain Control</b>	30 dB (+1 dB steps)	60 dB (+1 dB steps)
<b>Gain Range</b>	50 dB to 90 dB	50 dB to 90 dB
<b>Operating Temperature</b>	14°F to 122°F (-10°C to 50°C)	14°F to 122°F (-10°C to 50°C)
<b>Size &amp; Weight</b>	Small: 15 x 12 x 6.7 in, 25 lbs (typical) Large: 19 x 18 x 6.7 in, 40 lbs (typical)	Small: 15 x 12 x 6.7 in, 25 lbs (typical) Large: 19 x 18 x 6.7 in, 40 lbs (typical)

RF output levels will vary depending on band. Typical output levels for 700 and 800 Hz systems are 1 watt (nominal). VHF and UHF systems will vary depending on complexity of the spectrum. The output power will be defined by applications engineering in the proposal.

The following section provides context for how the Public safety DAS function, covering system topology and block diagrams for distinct functional blocks and features.

## Theory of Operation

1. An antenna receives the signal off-air and it is passed through a pre-selector filter and amplifier.
2. The low noise amplifier (Ex. DL LNA) boosts the incoming pre-selected frequencies.
3. The signal is then passed into either a channelizer card or a filtered amplifier card.
  - A channelizer card is an analog superheterodyne receiver and amplifier. The incoming broadband signal is split and distributed amongst multiple cards.
  - The channel cards mix down the signal to an intermediate frequency (IF). The signal is passed through a narrow-band filter with a bandwidth of 75KHz for Class A operation, or a wider bandwidth depending on the installation requirements.
  - Each card, labeled “sub-band” above, can either be a channelizer card, which filters an individual frequency (Class A) with a pass band of 75kHz or less, or a channel card configured with a wider sub-band pass band with bandwidth of > 75kHz (Class B).
  - Channel cards are available with bandwidths from 15kHz to 9MHz.
  - Alternatively, a filtered amplifier card operates at RF only and uses conventional filters to filter the signal.
  - After the sub-band cards, all undesired frequencies and spurious emissions are eliminated and only the desired frequencies remain.
4. A power amplifier located within the channel card boosts the signal to the desired level. A single channel amplifier can be used where appropriate. More commonly, a multi-carrier power amplifier is used to amplify multiple frequencies together.
5. Filtering is used in the last stage to eliminate harmonics and spurious by-products.
6. Multiple parallel cards as shown are tuned to different frequencies or wider sub-bands. Their outputs are combined into one multi-carrier signal and connected to a duplexer and then antenna.

In conclusion, two types of amplification systems can be used: a filtered amplifier card which operates on frequency with low noise amplifiers and appropriate RF filtering, or, when very sharp filtering is needed, strong in-band interferers exist, or when single channel Class A performance is required, channelizer card technology will be employed.

# System Topology (SAFE-1020 Fiber System)

The SAFE-1020 system communicates over fiber. The remote units (SAFE-1015) report their configuration and alarm data to the head-end (SAFE-1020).

The head-end then annunciates alarms via its NFPA relay outputs. The remote units also report their own alarms to the NFPA alarm outputs on the remote front panel.

The configuration is factory set and must be requested at the time of ordering.

- ① SAFE-1020 head-end off-air channelizer
- ② Donor antenna
- ③ Remote annunciator
- ④ Power supply and battery backup (BBU)
- ⑤ 120VAC power input
- ⑥ Network management system (NMS)
- ⑦ Service (in-building) antenna
- ⑧ SAFE-1015 remote unit

## Star Topology

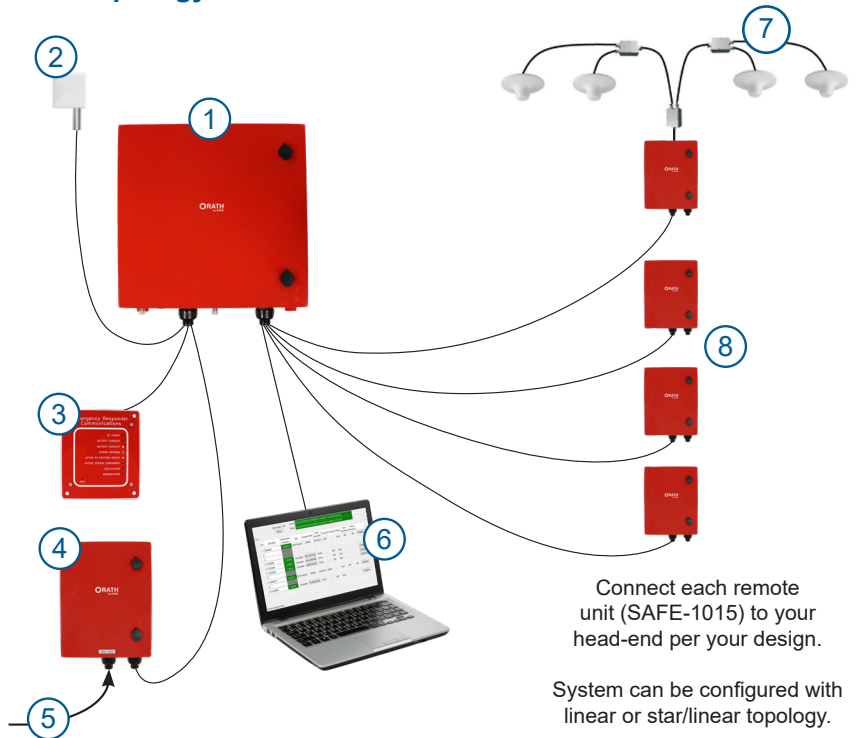

## Linear Topology

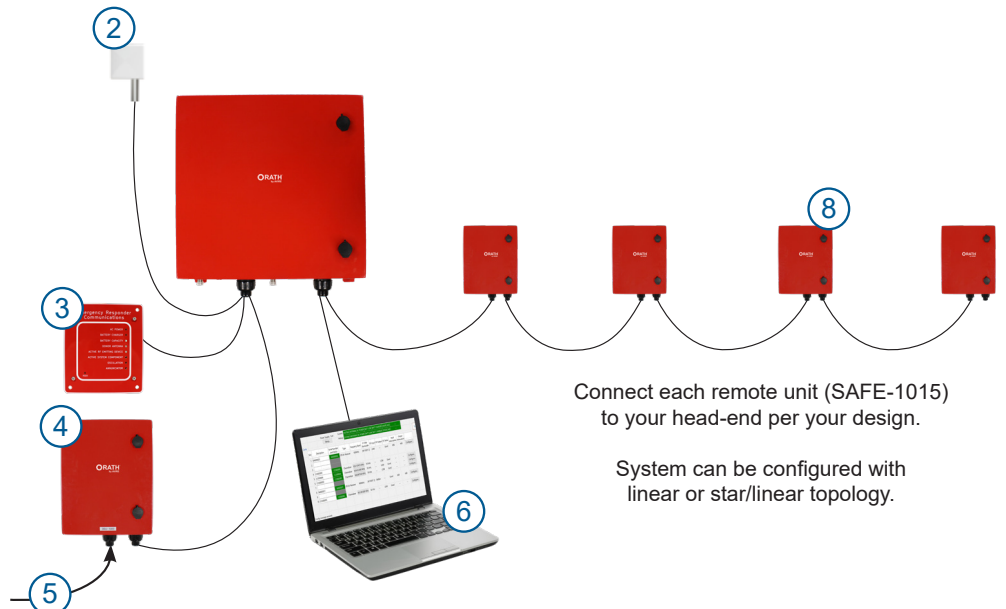

## System Topology (SAFE-1030)

The SAFE-1030 system communicates over air to the antenna network and is connected to the donor antenna via coaxial cable.

The head-end then annunciates alarms via its NFPA relay outputs and the NMS software. The remote units also report their own alarms to the NFPA alarm outputs on the remote front panel.

The configuration is factory set and must be requested at the time of ordering.

### Door Antenna

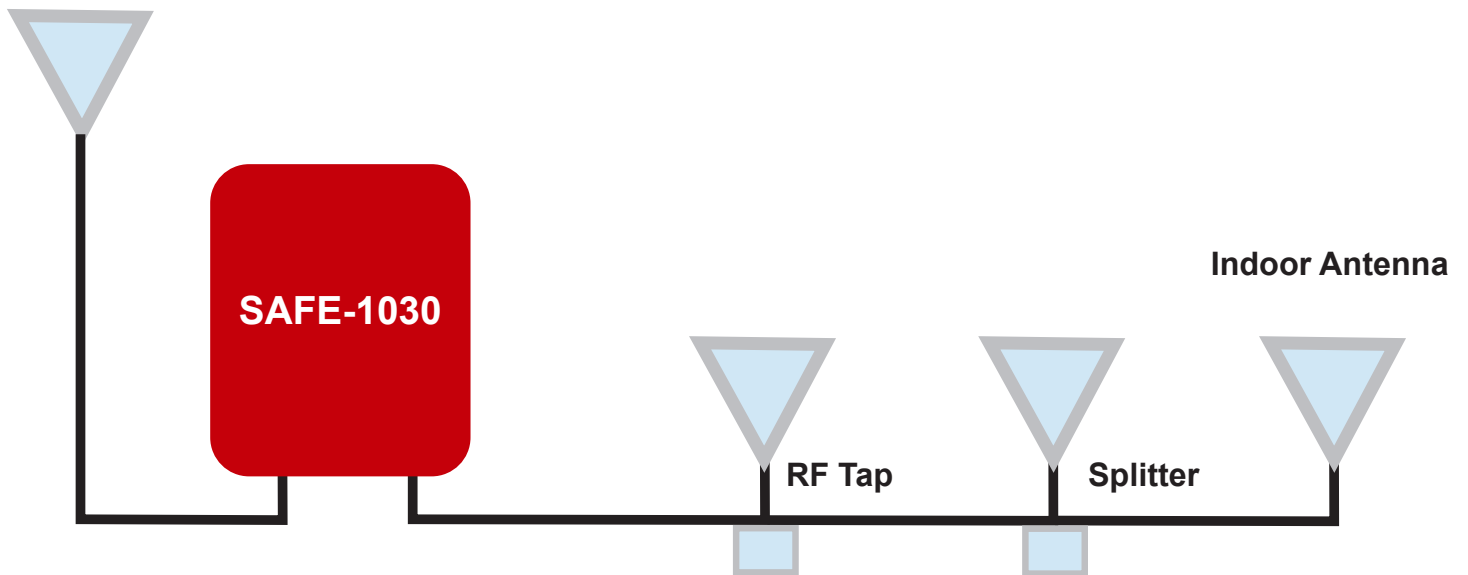

# System Block Diagrams

The block diagram can vary widely based on the number of bands, the frequencies, and the filter bandwidth required (Class A, Class B and its variants).

## SAFE-1020 Fiber System Example

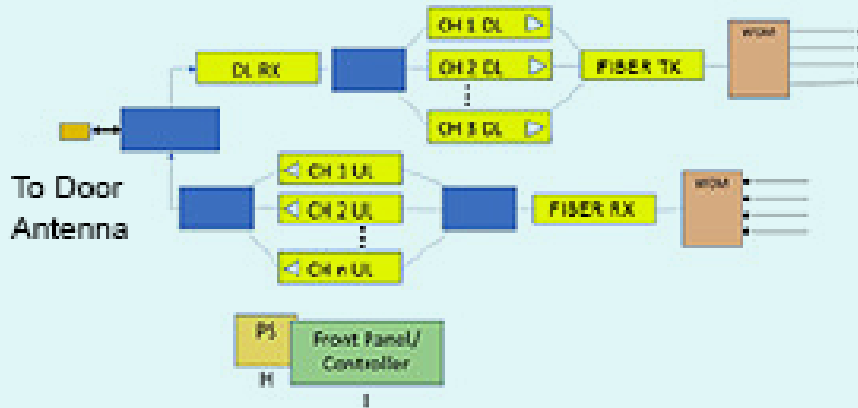

SAFE-1020 Class A/B Fiber DAS Head-End

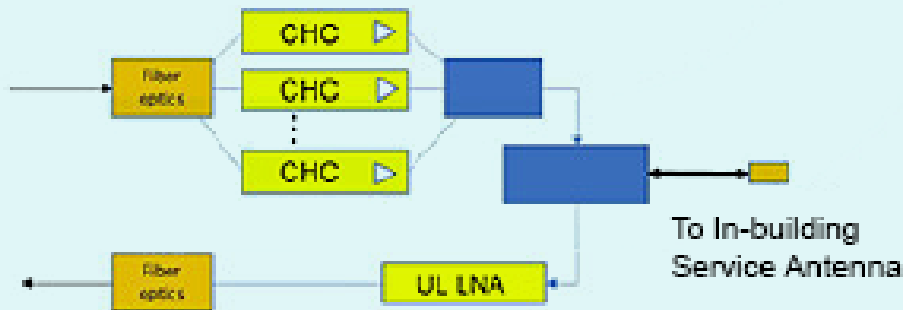

## SAFE-1030 System Example

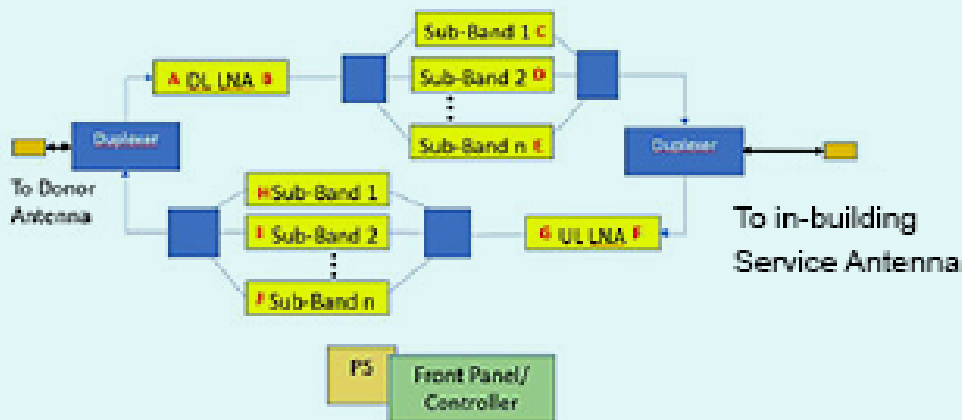

## System Functional Blocks and Features

The key functional blocks and front panel features are described below. Refer to the block diagrams and the front panel photos.

- A. Donor RF port – outdoor (N type-F) - Max. input -10 dBm
- B. Downlink LNA receiver card
- C. Sub-band Card: channelizer filter and amplifier or filtered amplifier card. Note: Only the channelizer card is tunable via the NMS. The filtered amplifier card is set at the factory.)
- D. In-building service antenna port (N type-F) - Max. input -10 dBm
- E. Uplink LNA receiver card
- F. Sub-band card – channelizer filter and amplifier card or filtered amplifier at frequency Note: Channel card (“channelizer”) is tunable via the network management system (NMS) software
- G. Front panel - +12VDC (default) or AC 120VAC input (varies per requirement, typically the AC supply is housed in the BBU and the BDA accepts +12VDC)
- H. Power supply – system controller, USB interface and alarm ports
- I. DC input & external alarm inputs via 8-pin Molex connector - external alarm inputs: Pin 1 - aux. alarm in; Pin 2 - battery charger alarm in; Pin 3 - battery low level alarm in; Pin 4 - AC alarm in (alarm active low = 0 VDC, all good = 5 VDC; compatible with SAFE-BBU-1000); Pins 5 & 6 - +12 VDC in; Pins 7 & 8 - GND
- J. Alarm outputs – Form C contact closure (see “Alarm Connector Pinouts”)
- K. USB port or Ethernet port, power switch, IR door sensor

## Signal Level Control Points

As shown in the block diagram:

- Items A & F control the input sensitivity of off-air receivers (OARX). These are set to minimum attenuation for maximum sensitivity or increased attenuation to prevent constant overload in cases where the uplink may experience strong signals.
- Items C, D, E, H, I, J are the gain setting attenuators. These are set to achieve the optimal level of gain and output level in the system. These attenuators are set in the factory and in most cases will not need to be adjusted. The system has a wide ranging AGC and ALC that will automatically adjust its gain to accommodate a wide range of signal levels.

## Section 3

## Inside Your Enclosure

The inside of your enclosure is configured to your unique specifications, where each cabinet may look different than another, but contains the same categories of components.

Each cabinet contains a “front panel” that acts as the main control interface to the unit and a set of “cards” or “channelizer cards” required to support your frequency bands and methods of connection/distribution (fiber or coaxial cable).

**Small enclosures are used for configurations requiring 10 or fewer cards.**



**Large enclosures are used when more bands/frequencies are supported.**

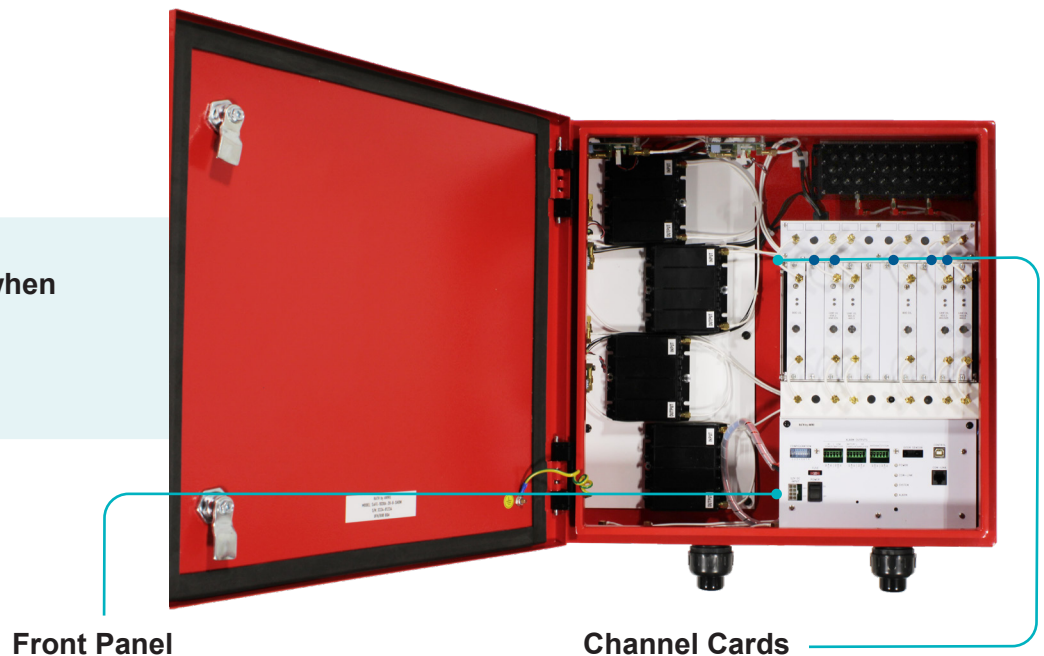

# Front Panel

- ① 8-pin input DC power and alarm connector
- ② Alarm outputs
- ③ Battery Backup Unit alarm inputs
- ④ System status LEDs
- ⑤ USB and NMS connection port(s)
- ⑥ Master on/off switch

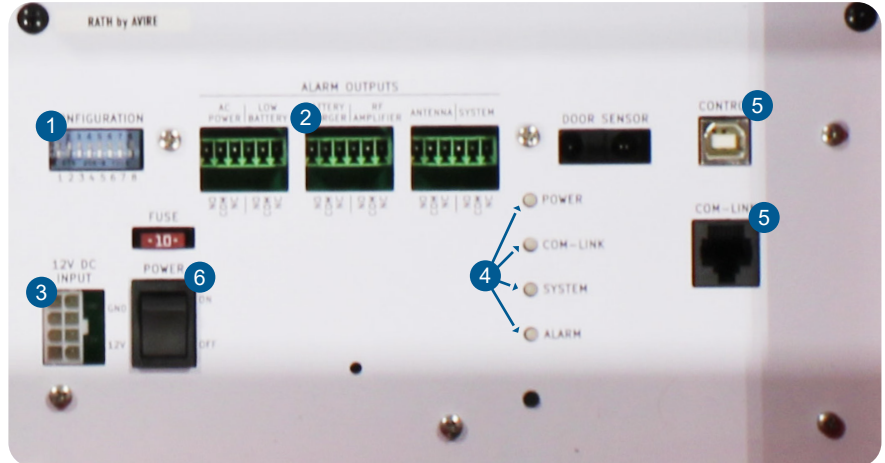

The front panel is the main control interface to the unit.

It contains:

1. 8-pin input DC power & alarm connector (also referred to as a DIP switch)
2. Alarm outputs (form C relays for NFPA alarms)
  - Power AMP alarm (Oscillation and AMP fail - over current or under current)
  - Battery charger alarm
  - Low battery alarm
  - Loss of AC alarm
  - Donor antenna alarm
  - BDA (component fail) alarm
3. Battery Backup Unit Alarm Inputs:
  - +12V DC
  - GND
  - 4 alarm inputs (right column pins, top to bottom)\*
    - Auxiliary input – an additional alarm triggered by a 0 – 5V input at the BBU
    - Battery charger alarm input (0 or 5V - Active low)
    - Low battery level alarm input (0 or 5V - Active low)
    - Loss of AC alarm input (0 or 5V - Active low)
4. System status LEDs
5. USB and NMS connection ports
6. Master ON/OFF switch (power)

\* **Note:** All alarm inputs are 0 to 5 volts (active high) and are compatible with the SAFE-BBU battery backup unit output.

\*\* **Note:** Depending on system configuration of the BDA (bands, channel count, etc.), a row of SMA connectors will be mounted onto the front panel directly or on a tray spanning the front panel under the card cage. The SMA connectors will be connected to the plug-in cards above at the factory. These SMA connectors will be connected to the plug-in cards above at the factory.

## Modular Card System (Channel Cards)

Public safety DAS use modular plug-in cards to configure a BDA or head-end. Each card can be one of several types:

- Channelizer card tunable over frequency range and AGC (bandwidth is factory set: 15kHz to 9MHz options)
- Filtered amplifier card (with band filtering and level control)
- Single carrier power AMP
- Fiber optic transmitter (with level control and band filtering)
- Fiber optic receiver (with level control and band filtering)



The examples shown here:

- Channelizer card
- Fiber optic transmitter. The fiber transmitter / receiver may also have a center connector that passes the subcarrier RF channel which is used for data and alarm communications between units in a fiber DAS

Each card has 2 LEDs that can illuminate red, yellow or green:

- On the channelizer and LNA, the green LED indicates there is RF power in the band.
- On the fiber optic cards, the green LED is a DC power indicator. It is on always.
- The yellow LED indicates the data communications activity between the card and the system controller.
- Flashing red LED = communication error

## Section 4

## Enclosure Installation

Installation environments and conditions may vary greatly from building to building. For specific questions regarding your building, please contact our Applications Engineering team.

### BDA and BBU Proximity

The BDA or head-end and the battery backup unit (BBU) must be mounted close together, as they are connected via a 6 foot 8-pin power cable that provides power to the BDA or head-end, through the BBU.

### Enclosure Mounting

The various components of the Public safety DAS line of distributed antenna systems can be mounted indoor or outdoor, in an enclosed, dry space, within a temperature range 14 to 122F (-10 to 50C)

Four ¼ inch LAG Screws are to be used when mounting the unit to ½” plywood.



1” punched square tube can be used as a spacer between the NEMA unit and the wall.



When mounting the enclosures, it is critical to provide spacers between the unit and the wall or mounting panel. A one-inch space is appropriate to allow for good air flow.

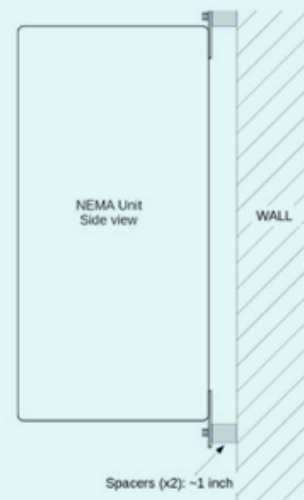

For pluggable equipment, the socket outlet shall be easily accessible. Proper strain relief is required on all electrical connections to the unit.

## Section 5

# Electrical Wiring and Components

**WARNING:** All wiring must be performed by an authorized, licensed contractor in accordance with the local jurisdictions' code and compliant with the National Electrical Code.

The items used to connect the Public safety DAS components include:

Provided by RATH®:

- One 6 foot 8-pin power cable that provides power to the BDA, from the BBU.
- Three 6-pin plugs, used to connect alarm wire and end-of-line termination resistors for the fire panel.
- One USB stick with Network Management System (NMS) software.
- One USB (USB-A to USB-B) cord to connect front panel to computer for NMS programming.

The following items must be supplied by the customer or licensed contractor:

- Fiber line used for the SAFE-1020/SAFE-1015. (Fiber DAS is an industry-standard single mode fiber 9/125um.
- The connectors used are industry standard SC/APC (typically green colored).
- Coaxial cable for the SAFE-1030.
- Alarm wires and end-of-line (EOL) termination resistors (Each 6-pin plug accepts a wire size of 18 to 26 gauge with room for an EOL resistor.)
- If using the SAFE-AN-1002 remote annunciators (recommended), connect to the BDA or head-end using 4 pair, 24AWG CAT5 wire.

## Section 6

# Battery Backup Unit (BBU) Installation & Connection

Each system is supported by a battery backup unit, which functions as both a pass through for primary power and provides backup power.

## Battery Backup Unit (BBU) Overview

The battery backup unit (BBU) provides 12 or 24-hour backup power and will come with 1 battery pack and a small enclosure or 2 battery packs and a large enclosure, based on system power consumption calculations and/or local requirements.

The battery backup unit features a lower control panel with AC power input, a power switch, 12V DC power output port (to connect to the BDA or head-end), alarm inputs, and LED indicators.



## Battery Pack Installation

1. Attach the included 4-wire battery cable to the battery pack as shown at right.
2. Install the battery pack on the right side of the BBU shelf, with the cable to the front side of the battery pack. Larger systems may require 2 battery packs.
3. Connect the other end of the battery cable to the right battery input port on the front panel (for single packs).
4. Secure the battery pack using the included white retention bracket by inserting the flat edge of the bracket into the guide slot at the top, then securing the bottom of the bracket to the battery shelf using the #6 - 32 screw provided.
5. If the BBU requires a second battery pack, repeat the installation on the left side of the BBU shelf, and connect the battery cable to the left battery input port on the front panel.



## Connecting to Power and the BDA

1. Connect AC power to the BBU "AC power input" terminals with three wires: line, neutral and ground. Maximum power is 200 watts so choose conductor size appropriately. (See image to the right.)
2. After the AC connections are secured, install the provided terminal block cover over the exposed contacts. Secure the AC cable to the black cable mount in the center of the panel. Note: The BBU requires AC power to turn on initially.
3. With the BBU system power switch in the off position, connect the provided 8-pin power cable from the BBU 12V power output port to the BDA 12V input port.
4. First turn the BBU power switch on, then turn the BDA power switch on. Follow this sequence any time the BBU system power switch is turned on.
5. The BBU LED status indicators should be the state 1 upon initial power-up. See "LED Indicators" below.

### LED Indicators

AC POWER	●	●	●	●	●	●	○	○	○	○
BATTERY	●	●	●	●	●	●	○	○	○	○
STATUS	●	●	●	●	●	●	○	○	○	○
STATE	1	2	3	4	5	6	7	8	9	10

- Grey Circle indicates LED off.
- White Dotted Circle indicates LED may flash red or green depending on current state when alarm occurred.
- Dashed Circle indicates flashing LED.

### State Descriptions

1. AC on, battery charging/balancing.
2. AC on, battery charged.
3. AC off, battery powered.
4. AC on, charger failure (not connected).
5. AC off, low battery voltage: (slow red/green flash).
6. External AUX alarm active.
7. External EPO engaged.
8. Battery over current.
9. Battery error: fast flashing (battery and status LEDs indicate blown fuse or cell out of range).

## BBU Front Panel

### Port Diagram

The "AUX" alarm can be used to trigger the BDA system alarm from a third-party device such as a motion detector or a room door switch. An external normally open contact is required to be connected between the "AUX NO" and "GND" terminals.

The Emergency Power Off (EPO) feature requires an external normally open switch. When the switch is closed, the BBU will cut off the DC power to the BDA. Connect the NO switch to the terminal labeled "GND" and "EPO NO". (A normally closed external switch option is available as a factory setting.)

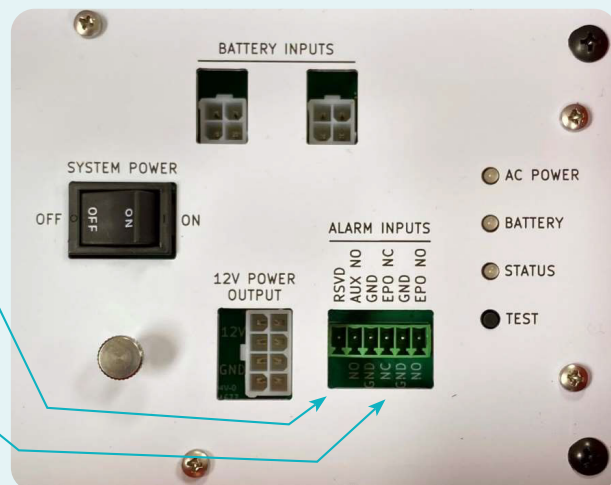

## Section 7

# System Alarms Overview and Connection

Each system includes connections for the NFPA required alarms, which monitor system performance related to power and component connections. Installers are provided with plugs for connecting the wires to the front panel of the BDA or head-end.

## Relay Alarm Connector Pinouts



6 form C relays, found on the front panel, are available for the standard NFPA alarms:

1. Power AMP alarm (Oscillation and AMP fail - over current or under current)
2. Battery charger alarm
3. Low battery alarm
4. Loss of AC alarm
5. Donor antenna alarm
6. BDA (component fail) alarm

“Form C” indicates that each alarm relay output has 3 ports: common, normally open (NO) and normally closed (NC). The user selects which 2 ports to use depending on the fire panel requirements:

- Common and NO (an alarm condition causes the normally open relay to close)
- Common and NC (an alarm condition causes the normally closed relay to open)

**Note:** The backup battery unit alarms are delivered to the BDA over the supplied 8-pin cable jumper. All NFPA alarms (the battery and BDA alarms) are annunciated via the BDA.

## Pinout

The 18 positions, from left to right, are:

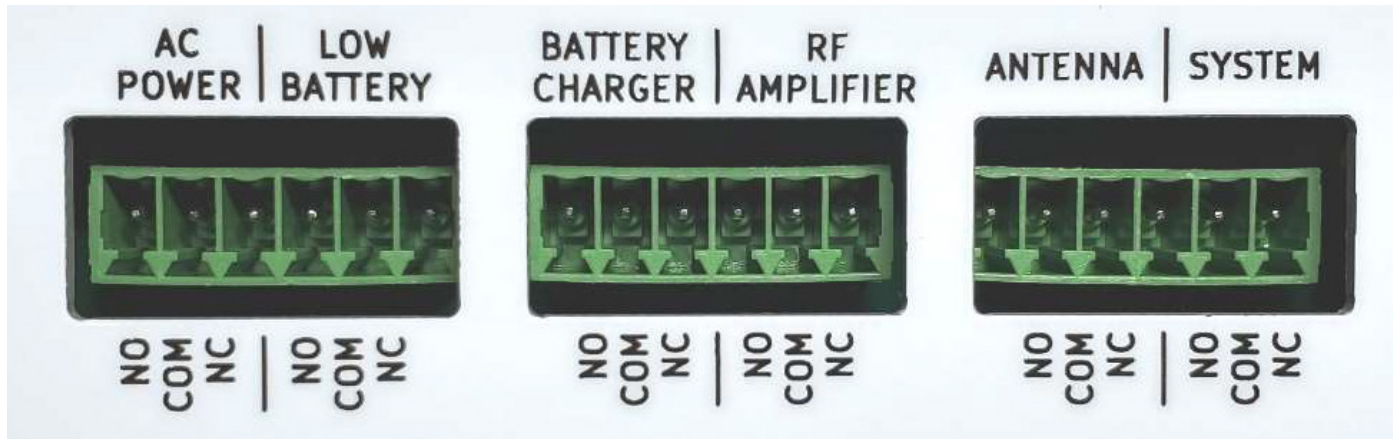

## Plugs

Three 6-pin plugs are provided with each system. They are used to connect alarm wire and end-of-line termination resistors for the fire panel.

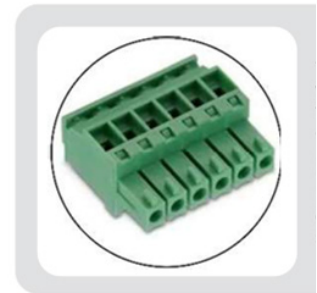

## Connecting the NFPA Alarms

1. Insert the alarm wires and end-of-line (EOL) termination resistors, as required, into one of the 6-pin plugs provided, aligned to the appropriate position on the pinout.
  - a. Each plug accepts a wire size of 18 to 26 gauge with room for an EOL resistor.
  - b. Connect 2 wires: One to the common port and one to either the NO or NC, depending on the fire panel requirements for normally open (NO) or normally closed (NC) relay inputs.
  - c. Using a small screwdriver, tighten the wires into place.
2. Once wired, press each plug into the appropriate jack on the front panel.

**Note:** The BDA or “system” output relay is a catch-all alarm. It will trigger with the triggering of any of the other alarms. Therefore, it can be used as a single summary connection to the fire panel .

## Alarm Activation

The 8-pin input DC power & alarm connector, also known as the DIP switch, is also found on the front panel.

**Once wiring is complete, the alarms are activated by turning all the switches in the first 5 positions on the DIP switch to the “up” position. They can be disabled by turning the switches to the down position.**



The DIP switches control the alarms as follows (from left to right):

- |                                                               |                                       |
|---------------------------------------------------------------|---------------------------------------|
| 1. Audible beep                                               | 4. Antenna alarm                      |
| 2. All BBU alarms (Low battery level, charger fail & AC fail) | 5. Door alarm                         |
| 3. Amp alarm (Oscillation and amp current detect alarm)       | 6. Reserved – keep OFF (clicked down) |
|                                                               | 7 & 8. Remote annunciator             |

## Door Sensor

An IR emitter and sensor monitors the door of the enclosure. When the door opens, the sensor will trigger the door alarm and in turn the BDA output relay alarm.

## Section 8

## Power Up Your System

The BDA enclosures are grounded to the electrical ground terminals internally. The user must ensure that the earth ground connection at the terminal strip or the grounding lug on the outside of the enclosure is properly connected to the external earth ground.

1. Ground all units properly via the DC or AC input terminal.
2. Connect all units with power.
3. Turn on the BBU using the system power switch on the control panel.
4. Turn on the BDA using the system power switch on the front panel.
5. Confirm the frequencies are set properly via the NMS (see next section).
  - The frequencies should have been programmed at the factory, but the installer must always confirm the correct settings once the equipment is in the field.

### Battery Backup Unit (BBU)

The “system power” switch is located on the lower control panel of the battery backup unit: flip it to the “on” position.



### Bi-Directional Amplifier (BDA)

The “system power” switch is located on the front panel of the BDA: flip it to the “on” position.



Test the following alarms related to the battery backup unit:

### **Low Battery Voltage Level Alarm:**

1. Disconnect the 4-wire cable jumper that runs between the battery and the front panel. This will trigger a low battery level alarm.
2. Reconnect the cable to clear the alarm.

**Note:** If two battery packs are installed, both must be disconnected to trigger the alarm. Always keep the two batteries at a similar charge level. If the two batteries are at a different charge level, you can experience a larger surge of current between the two batteries upon connecting them. This is undesirable and could damage the equipment.

### **Battery Charger Alarm:**

Press “TEST” button on front panel (located under the LEDs). This will trigger the battery charger fail alarm. Press again to reset alarm.

### **AC Power Alarm:**

Disconnect AC power source. This will trigger the AC alarm. Reconnect AC power to reset alarm.

This version of the Network Management System (NMS) software runs locally on a Windows PC and allows you to interact with (configure and monitor) the BDA or fiber DAS head-end, remote units and all associated alarms.

## Getting started

- 1. Locate the USB memory stick:** The software is provided on a red USB memory stick that is attached to the front panel of the BDA or head-end. If the USB memory stick is missing or lost, contact the Technical Support team for a secure link to download the software.
- 2. Confirm which operating system you are using:**
  - If using Windows 10 or later: All necessary drivers are provided by the operating system. The software will load and operate properly.
  - If using versions earlier than Windows 10: You may need additional drivers that are not available on an older operating system. Please contact Technical Support and the required drivers can be provided.
- 3. Install the software:** Plug the USB drive into your PC. Locate the corresponding drive and open it to reveal the software program. Click on it and follow the prompts to run and install the .exe file.
- 4. Pin it:** Once complete, pin the icon to your desktop or another convenient location for easy access if you choose.

## Section 11

# Connecting the BDA or Fiber DAS Units to the NMS

**Attention:** To connect the BDA or fiber DAS to your NMS software, the software must be loaded onto your PC (previous step). The BDA or fiber DAS should be powered on and your PC connected to the BDA using USB (USB-A to USB-B) cable provided with your equipment. (You will need to be in the location of the BDA or head-end.)

1. Using the USB cord provided (6 ft), connect your Windows PC to the BDA/head-end front panel.
2. On your computer, open the Network Management Software. The screen below will be displayed, opening on the “Configuration” tab.

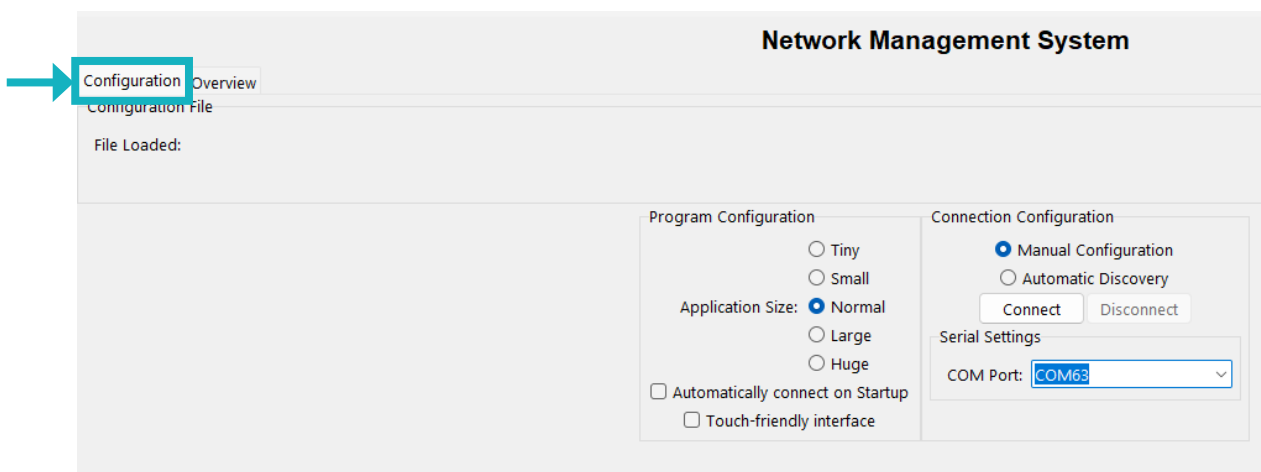

3. Select “Manual Configuration” and use the drop-down box to select your COM Port.

**Note:** The software will always present 2 COM Ports. One is used for internal factory setup. The other is the COM Port you will use. You may need to try both to determine the correct port (this is a Windows 10 limitation).

4. Once the COM Port is selected, click the “Connect” button to pair the software with the SAFE-1030 BDA or fiber DAS (SAFE-1020/SAFE-1015).
5. If the COM Port you selected doesn’t open the BDA Overview window shown below, click “Disconnect” and try the other COM Port.

## Connecting a SAFE-1030 BDA

Once the connection to the BDA is complete, the software will automatically advance to the “Overview” tab.

Verify your system information:

- Your BDA description and serial number will appear in the table on the “Overview” screen.
- The “Alarms” next to the BDA should be green, indicating they have been set up, but no alarms have been triggered in the system.
- If the alarms boxes are gray, they have not been set up.
- Once operational, any triggered alarm within the BDA or its associated battery backup system would turn the boxes red.

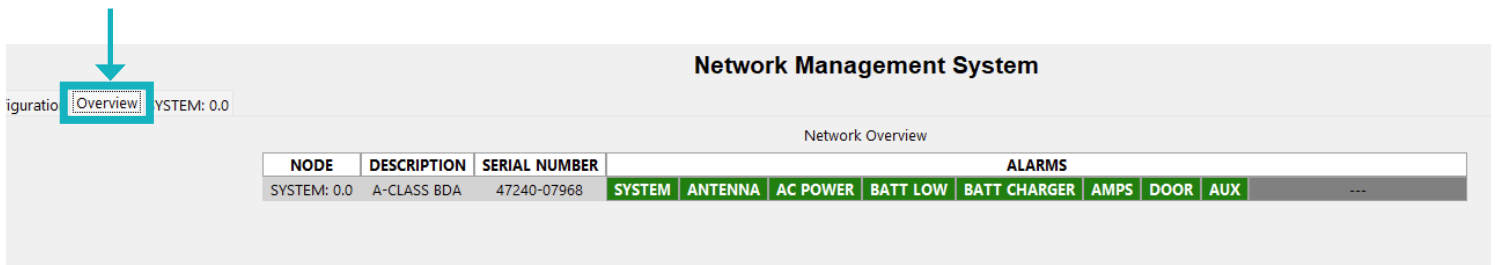

Configuration SYSTEM: 0.0

Network Management System

Network Overview

NODE	DESCRIPTION	SERIAL NUMBER	ALARMS								
SYSTEM: 0.0	A-CLASS BDA	47240-07968	SYSTEM	ANTENNA	AC POWER	BATT LOW	BATT CHARGER	AMPS	DOOR	AUX	---

**Note:** If the system did not connect, click on the other COM Port as referenced in Step 3. If neither COM Port connects, check to ensure the BDA is powered up and the cable connections are secure. If the BDA was not turned on when you clicked “Connect” you may need to click on “Disconnect” close the program and restart and try the other COM Port.

## Connecting a SAFE-1020/SAFE-1015 Fiber DAS

The software will identify the head-end (SAFE-1020) and all remote units (SAFE-1015) and automatically advance to the “Overview” tab once the connection is complete.

Verify your system information:

- In the case of a fiber DAS, the “Overview” tab will show all the units and serial numbers attached to the fiber network, including the SAFE-1020 head-end and any SAFE-1015 remote units.
- The “Alarms” next to each unit should be green, indicating the alarms have been set up, but no alarms have been triggered in the system.
  - If the alarms boxes are gray, they have not been set up.
  - Once operational, any triggered alarm within the BDA or its associated battery backup system would turn the boxes red.

### Network Management System

Configuration Overview SYSTEM: 0.0 SYSTEM: 1.1 SYSTEM: 1.2

Network Overview

NODE	DESCRIPTION	SERIAL NUMBER	ALARMS								
			SYSTEM	ANTENNA	AC POWER	BATT LOW	BATT CHARGER	AMPS	DOOR	AUX	
SYSTEM: 0.0	HEAD-END	12340-01234	SYSTEM	ANTENNA	AC POWER	BATT LOW	BATT CHARGER	AMPS	DOOR	AUX	---
SYSTEM: 1.1	REMOTE 1	47240-07839	SYSTEM	ANTENNA	AC POWER	BATT LOW	BATT CHARGER	AMPS	DOOR	AUX	---
SYSTEM: 1.2	REMOTE 2	47240-07842	SYSTEM	ANTENNA	AC POWER	BATT LOW	BATT CHARGER	AMPS	DOOR	AUX	---

Here we have an example of a head-end unit with two remotes.

**Note:** If the system did not connect, click on the other COM Port as referenced in Step 3. If neither COM Port connects, check to ensure the system is powered up and the cable connections are secure. If the BDA was not turned on when you clicked “Connect” you may need to click on “Disconnect” close the program and restart and try the other COM Port.

# Verifying Connection

1. Click on the 3rd tab (BDA or head-end).
2. Look for the flashing message:
  - When connected, each tab in the NMS will display a scrolling message in the bottom left corner to indicate the NMS is communicating properly with the BDA. The message will contain the product identification information and will scroll continuously.
  - If the message stops scrolling or does not appear, this is an indication that the USB connection has dropped. Restart the program.

**Network Management System**

Configuration Overview SYSTEM: 0.0

**A-CLASS BDA**      Setup...  
 SN:[47240-07968]      Power Supply: 11.8V  
 FW: v5.10.3.1590 Beta

Alarms

Current:	SYSTEM	ANTENNA	AC POWER	BATT LOW	BATT CHARGER	AMPS	DOOR	AUX	---
History:	SYSTEM	ANTENNA	AC POWER	BATT LOW	BATT CHARGER	AMPS	DOOR	AUX	---

Cage 1

SLOT	STATUS	DEVICE	DESCRIPTION	DIR	BAND	FILTER BW	RF INPUT	GAIN	TARGET OUT	RF OUTPUT	RF STATUS
1	GOOD	CHC 6.4	A-class 769-775 DL FW: v5.10.3.1525 Beta	DL	700 MHz	6000 kHz	-71 dBm	86 dB	25 dBm	14 dBm	ON
2	---										
3	---										
4	GOOD	CHC 6.4	A-class 851-861 DL FW: v5.10.3.1525 Beta	DL	800 MHz	10000 kHz	--	--	25 dBm	--	SQUELCH
5	---										
6	---										
7	GOOD	CHC 6.4	A-class 799-816 UL FW: v5.10.2.1525 Beta	UL	700 MHz	16000 kHz	--	84 dB	22 dBm	-7 dBm	ON
8	---										
9	---										
10	---										

PORT	STATUS	DEVICE	DESCRIPTION	DIR	BAND	AMP STATUS	RF INPUT	GAIN	TARGET OUT	RF OUTPUT	RF STATUS
A	GOOD	DFA 1.2	GT Kinyas Joel FW: v6.0.0.1010 Beta								
B	GOOD	PAC 3.3	700MHz DL POWER AMP FW: v5.10.3.1525 Beta	DL	700 MHz	ON	--				ON
C	GOOD	PAC 3.3	800MHz DL POWER AMP FW: v5.10.3.1525 Beta	DL	800 MHz	ON	--				ON
D	GOOD	PAC 3.3	7/800 UL POWER AMP FW: v5.10.3.1525 Beta	UL	700/800 MHz	ON	--				ON
PIO	GOOD	PIO 5.5	PWR-IO FRONT PANEL FW: v5.10.0.1324 Beta								

ANTENNA 1  
700/800 MHz  
**GOOD**

Received: [SYSTEM: 0.0-1] SN:47240-07968 DVC:SYS RecordEndOfList-v5

- Note:** If the USB connection has dropped:
1. Check to ensure the USB cord is still plugged in to both the front panel of the BDA/head-end and your laptop and that the system is still powered on.
  2. Revert to the first "Configuration" tab and repeat the connection steps to reconnect to the BDA or fiber DAS.
  3. If that does not work, you may need to close the program and restart, then repeat the steps to connect.

## Section 12

# System Operation (Notifications & Alarms)

After the system is installed and is operational, LED notifications on the front panel will indicate system status. System alarms can be silenced for maintenance as needed.

## LED Notifications

When operating normally, the “power” and “system” LEDs found in the front panel will be green. The other front panel LED’s will be off.

When the system is actively transmitting a signal, the LED on the applicable plug-in channel card(s) will be green. It will be off when not transmitting.

When any of the alarms are activated, the “alarm” LED on the front panel, and the “system” LED will be red.



The top 3 LEDs on the front panel, for AC Power, Battery and Status, can each be illuminated (green/red) or off, and can be illuminated in a constant state or blinking.

## Silencing Audible Alarms

To silence audible alarms, flip the DIP switch in the first (far left) position DOWN to disable the audible beeper.





**N56 W24720 N. Corporate Circle • Sussex, WI 53089**

**800-451-1460**

**[avire-global.com/en-us](http://avire-global.com/en-us)**