



Panachrome with Voice Wiring

Speech Unit Box

Power: Wire 110vac to the 24vac power supply that is mounted inside.
(See diagram on page 2)

Wire Connections between Speech Box and Panachrome Control Box:

1. Wire the positive terminal (+ 24vdc) from the power supply in the speech box to the COM terminal for the Aux relay inside the Panachrome control box.
2. Wire input 31 (door closing message) from speech board to N/C (Normally Closed) terminal for the Aux relay inside the Panachrome control box.
3. Wire Input 32 (door opening message) from speech board to N/O (Normally Open) terminal for the Aux relay inside the Panachrome control box.

Panachrome Control Box Dip Switch Settings:

1. SW5 Switch block- Switch 3 set to **ON**
2. SW6 Switch block – Switch 2 set to **ON**
3. Firmware Version- V4.0 OPT312

Panachrome/Speech Wiring

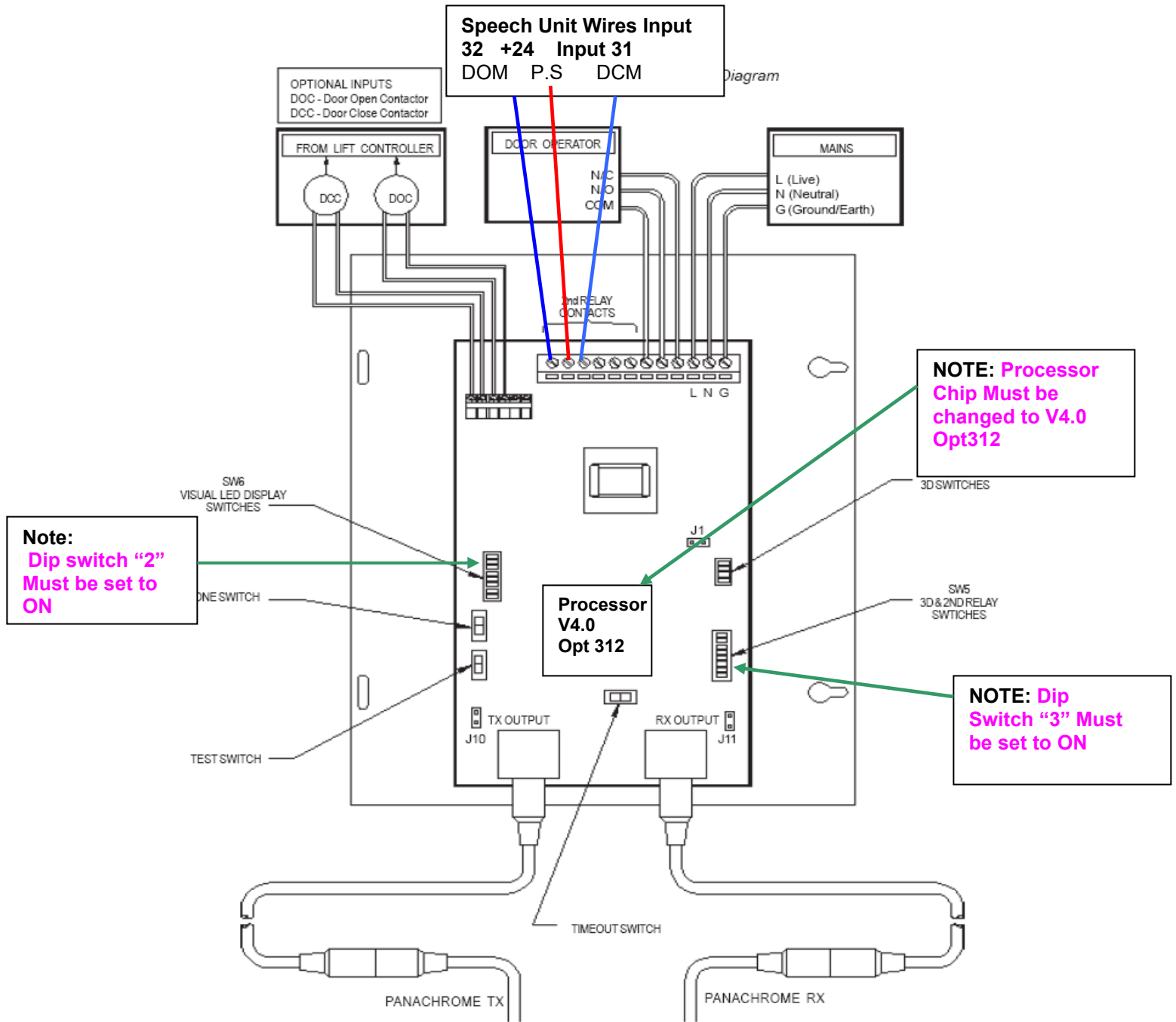

Speech Unit Wiring

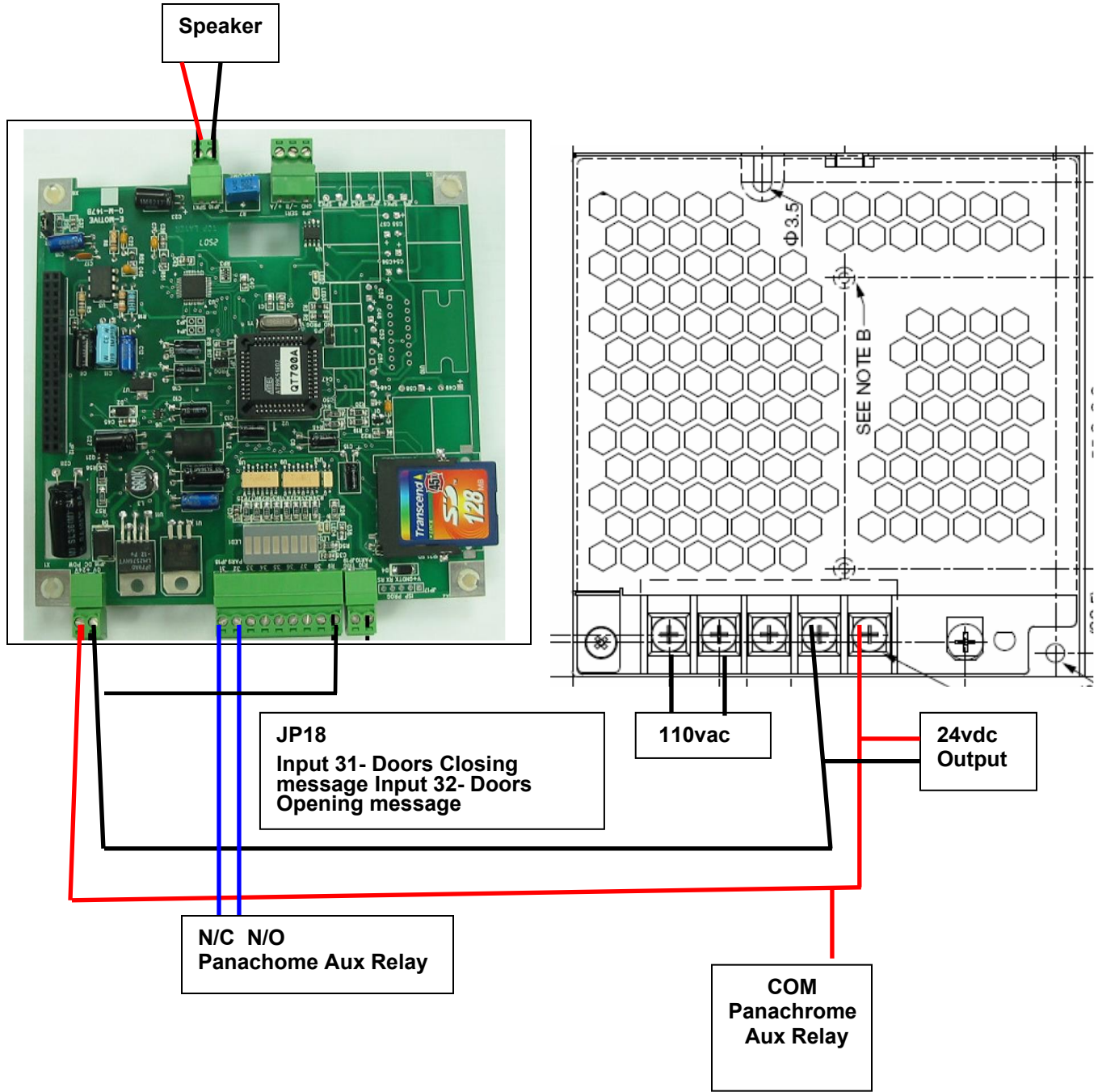

Panachrome / Voice Troubleshooting

Note: All dip switch settings inside the control box are factory set.

2D (Straight Across Beams) Fault: Turn on “Test Switch” to view fault codes on the LED display and refer to the “Troubleshooting Card” that is attached to the side of the Panachrome control box and follow the troubleshooting instructions on the card.

3D Fault: (Note: When troubleshooting the 3D portion, the elevator should be at floor level and not in between floors). If the doors close trigger at some point and reopen and a “3” appears on the display, follow the instruction below regarding installation and reducing the 3D sensitivity.

• **Check Installation:**

1. RX and TX are handed. When standing inside the hoistway, TX should be mounted on your left side and RX should be mounted on your right side.
2. RX and TX should not be recessed. When the doors are fully closed there should not be more than a ½” gap between both detectors.

Reduce Sensitivity: Use dip switch 3 & 4

See table below:

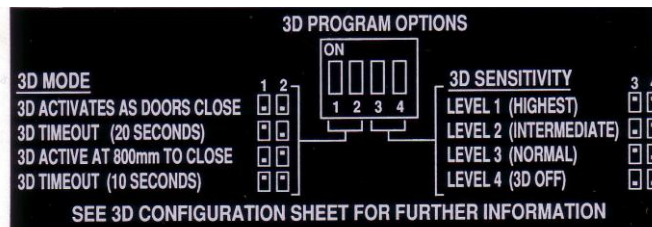

Voice Unit: When doors open do you see the detector green lights come on and does the door open message sound? Also, when the doors close do you see the detector red lights come on and the doors close message sound? If no, then check the following:

1. Installation- Check if unit is wired correctly by referring to the voice unit installation.

Panachrome Control Box Settings When Using Voice (Speech) Unit: SW6 Switch Block- Switch 2 set to “ON” – This will activate the automatic mode for the Red/Green Led Panachrome lights.

For further troubleshooting assistance, please contact Janus Technical Support at 800-527-9156.