



SHW-MRI-1 MACHINE ROOM INTERCOM USER'S MANUAL



SHW-MRI-1

984-0120
Rev 1
01/21

N56 W24720 N. Corporate Circle • Sussex, WI 53089
800-527-9156 • www.januselevator.com

Table of Contents

<u>Section</u>	<u>Page</u>
Overview	3
Installation	3
Operation	3
Troubleshooting	4
SHW-MRI-1 Connection Diagram	5
SHW-MRI-1 Mounting Diagram	6

Overview

The SHW-MRI-1 is an easy upgrade solution to provide two-way voice communications between the machine room and the elevator car using an existing elevator phone.

The SHW-MRI-1 is installed in the machine room, using the existing telephone line that is connected to the elevator phone. The telephone line is cut and the SHW-MRI-1 is connected in series to that line using the supplied phone jacks. The incoming phone jack connects to a C.O. or PBX phone line and the outgoing phone jack connects to the elevator phone.

The SHW-MRI-1 meets requirements for **ASME A17.1a 2001** addenda to **ASME A17.1-2000 Safety Code for Elevators and Escalators**.

2.27.1.3 Machine Room Communications:

A means of two-way communications between the car and the machine room shall be provided as required by 2.26.1.5.10(c).

Installation

1. The machine room intercom requires two pair of wires, one for the elevator phone and one for the phone line. The SHW-MRI-1 system requires 24VDC/0.5A to operate.

NOTE: Cabling can be inexpensive telephone communication cable, which is normally 20-22 gauge twisted pair. Through the travelling cable, you will need a twisted shielded pair with the shield grounded at the elevator controller or a good earth ground. The shield needs to be connected throughout the entire run including any splices and should only be grounded at the controller end.

2. Install the SHW-MRI-1 unit on the wall or flat surface with (4) 8-32 screws using the (4) keyholes on the back of the unit (see Figure 2).
3. Plug in the incoming phone line to the "Incoming" phone jack of the SHW-MRI-1 unit. If you don't have a modular connector on your phone line wires, you need to open up the "Incoming" phone jack and connect the incoming phone line to the Green and Red terminals of that jack. Close the jack when finished (see Figure 1).
4. Plug in the elevator phone to the "Outgoing" phone jack of the SHW-MRI-1 unit. If you don't have a modular connector on your phone wires, you need to open up the "Outgoing" phone jack and connect the elevator phone wires to the Green and Red terminals of that jack. Close the jack when finished (see Figure 1).

Operation

1. Pickup the handset on the SHW-MRI-1.
2. Press and hold the push button on the SHW-MRI-1 faceplate for at least three seconds.

3. The LED on the SHW-MRI-1 faceplate will start flashing and nothing will be heard through the phone. The flashing will continue at a faster rate for 4 seconds and then it will go out for 2 seconds. If the elevator phone is equipped with a ringer it will start ringing. This will continue until the elevator phone turns 'ON' automatically or someone actually answers the call.
4. When the elevator phone has turned 'ON' you will have two-way communication.
5. The call will be terminated when you hang up the phone on the SHW-MRI-1 unit or the elevator phone. The LED will start flashing again and then it will turn 'OFF'.
6. The SHW-MRI-1 and the elevator phone are now ready for normal operation.
NOTE: If the elevator phone is being used while the SHW-MRI-1 is trying to call the unit, the elevator phone will be disconnected from the phone line and automatically connected to the SHW-MRI-1 unit.

Troubleshooting

1. If the SHW-MRI-1 does not turn 'ON' make sure the wall transformer is plugged into 110VAC outlet, and measure the voltage on the "POWER" connector inside the SHW-MRI-1 unit. The voltage should read about 24-28VDC. The "POWER" connection is not polarity sensitive.
2. If the SHW-MRI-1 turns 'ON' but does not call the elevator phone, check all your connections according to Figure 1. Press the button to make a call and measure the maximum AC voltage coming from the elevator port using a voltmeter.
NOTE: The normal ring voltage generated by the SHW-MRI-1 unit is about 60-80VAC. **USE CAUTION WHEN MEASURING RING VOLTAGE ON THE LINE.**
3. If the elevator phone does not call out, check the voltage of the phone line on the "Telco" connector of the SHW-MRI-1 unit. The same voltage should be shown on the "Elev." connector of the SHW-MRI-1.
NOTE: The normal phone line voltage is about 24-52VDC. There are cases when the voltage might drop below 24VDC if the phone line connection is located far away from the central office or an internal phone system is used.
4. If the elevator phone (Janus phone) sounds low, you can call in and when the phone answers press 9 and listen for 3 beeps. You can repeat this step one more times to adjust the speaker volume to the maximum level. If you have an older EMS-HFP phone you can adjust the R13 (VOL.) potentiometer counter-clockwise to the max. If it's still low, add a 9 volt battery to the battery lead of the phone and try again.

SHW-MRI-1 Connection Diagram (Figure 1)

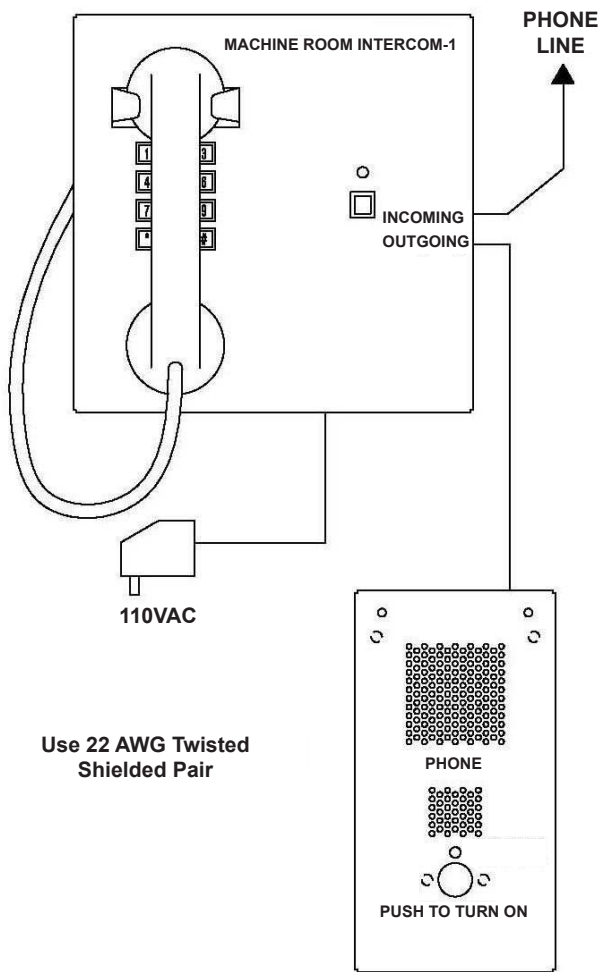

SHW-MRI-1 Mounting Diagram (Figure 2)

