



Pana(\$`D`i g&& # 8

Installation Guide

Detector Installation

The Pana40 Plus standard detectors have been designed so that they can be mounted flush with the leading edge, or as far back on the car door as required in order to deter vandalism.

The Pana40 Plus 3D detectors must be fitted flush with the door edge. This is to allow the infra-red light for 3D operation to project onto the landing.

Installation Notes 2D / 3D

1. Use fixing kits provided with the detectors, see below 'Mounting Diagram' different installations and mounting kits.
2. Detectors with the 'earth' wire must be fitted to ensure that the unit is properly grounded.
3. Plastic filter on 744 profiles has to be removed before mounting; this is done by removing top end cap screws and sliding filter out. Once detector is fitted, slide filter carefully back in with end cap.
4. Position the detectors on the doors approximately 5mm above the sill.
5. Mark or spot through the 5 fixing holes.
6. Remove the detectors from the door before drilling.
7. Screw the detector to the door using the fixing kits provided.
8. If the TX and RX detector positions are reversed only on 2D profile then countersunk screws can be used to screw the detector to the door.

Installation Notes 3D

1. The detectors must be installed 5mm above sill, and set no more than 10mm apart when the doors are fully closed and aligned within the detector's centre line. This is to ensure reliable operation of the 3D self-test that is performed when the doors have closed.
2. The 3D TX detector should be mounted on the left and the 3D RX on the right when viewed from the landing.
3. Detectors should be aligned as closely as possible for reliable operation.
4. 3D Switch Settings are detailed on the inside of the Main 3D Controller.

2D Fixtures

Detector Mounting Diagram for 740/770 Profiles

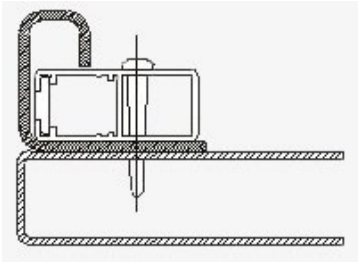

741 000 (has no external earth wire)
SightGuard and Self-Tapping Screw

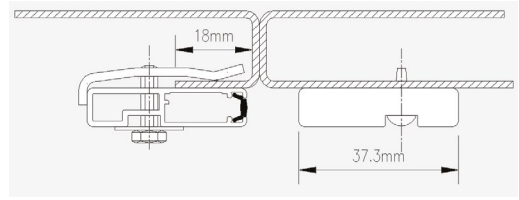

743 000 Fixing Clamp and Self-Tapping Screw

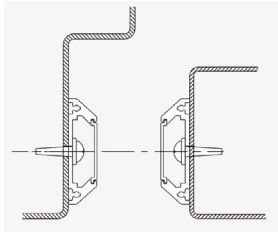

744 XXX (2m / 2.1m) Self-Tapping Screw

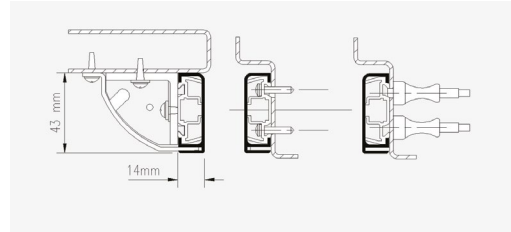

744 040 Self-Tapping Screw or Wing nut fixing for Slampost

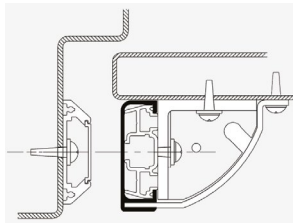

744 020 Self-Tapping Screw and standard fixing

3D Fixtures

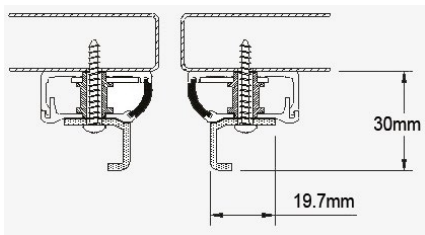

771 000 (has no external earth wire)
Finger guard with fixing screws

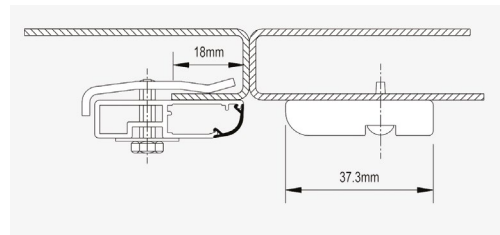

774 000 Fixing Clamp and Self-Tapping Screw

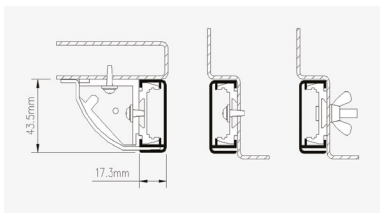

770 040 Self-Tapping Screw or Wing nut fixing for Slampost

Detector Mounting Diagram for 740 / 770 profiles

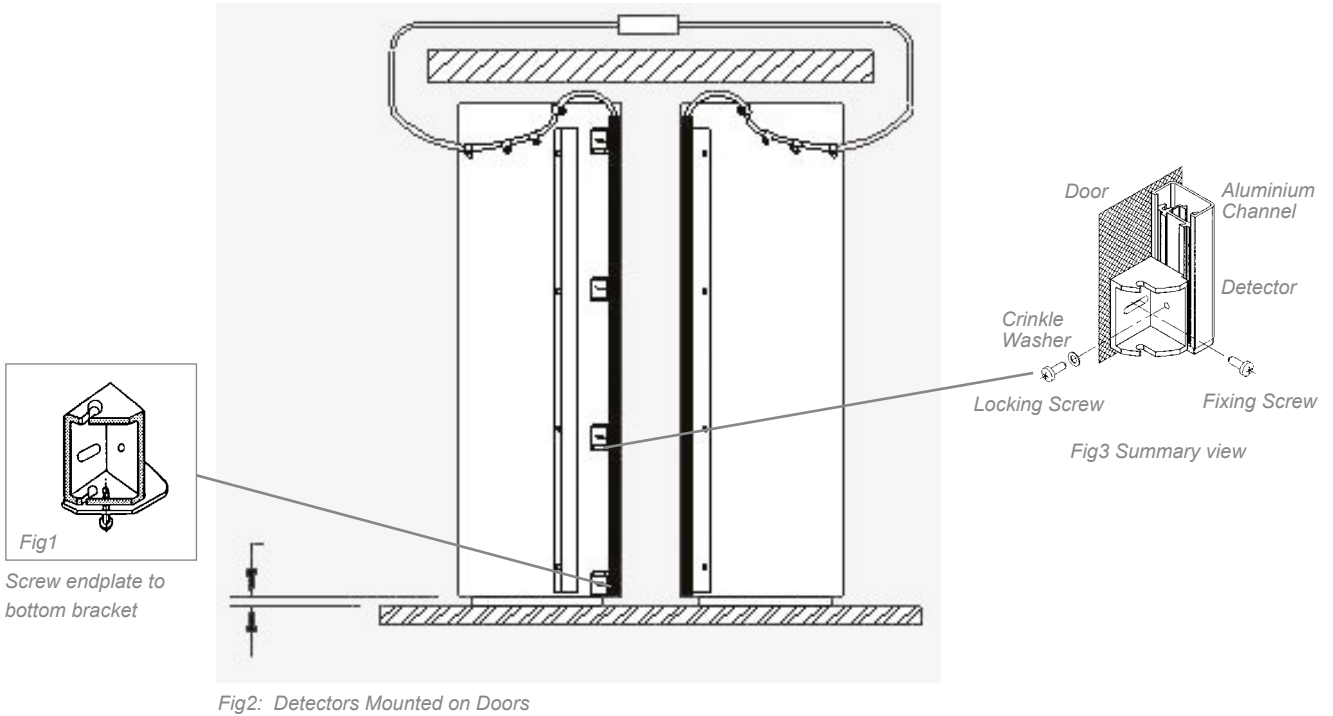

Detector Mounting Diagram for 741 / 743 / 771 / 774 profiles

The detectors should be screwed into place using 5 equidistant fixings as shown below:

Fig5

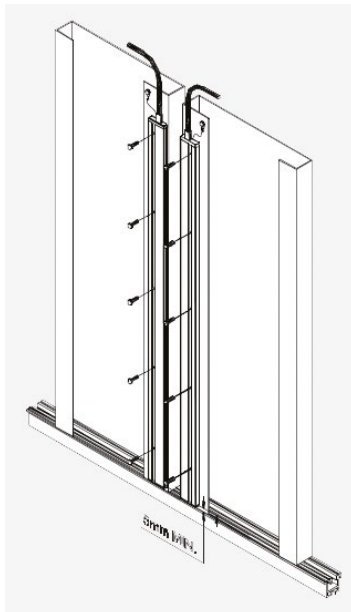

Step by Step Guide

Fitting Detector to Door (Center-Opening)

Step 1

Using the fixing kit provided with the detectors

See 'Mounting Diagrams' for different installations and mounting kit options

Step 2

Position the detectors on the doors approximately 5mm above car sill

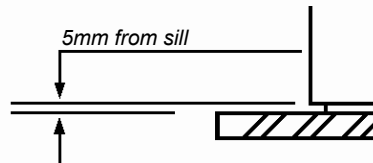

Step 3

Mark or spot through the 5 fixing holes

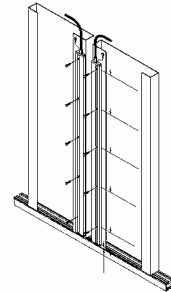

Step 5

Attach cable securely with the P-clips and screws provided. Avoid tight bends while providing enough slack so that cables are not stressed or stretched as the doors move.

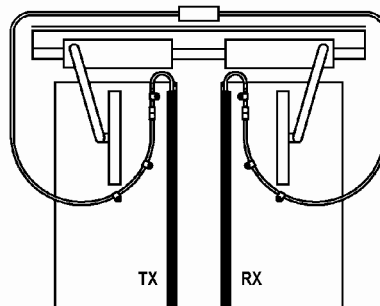

Step 4

Remove the detectors from the door before drilling,

Screw the detector to the door using the fixing kit provided

Static Kit Installation diagram for 2D Only

Installation Kit i 616 800-010 for installing a set of 9mm or 15mm profile detectors in a fixed position at either end of the lift car sill

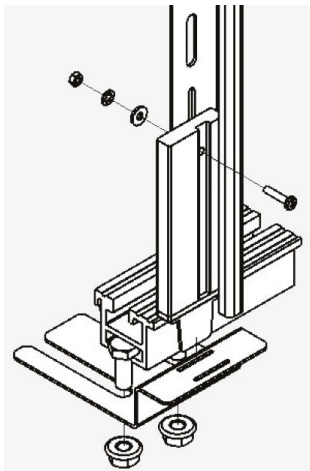

Sill Bracket attached to car sill

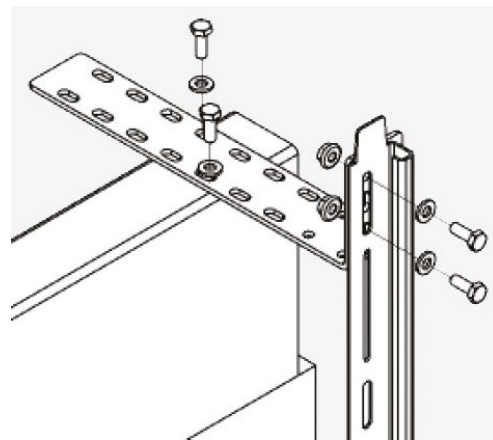

Short 'L' Bracket attached to Long Bracket

Long Bracket

This Long Bracket is effectively used to support the detector and increase its overall length so that it can be secured to the top of the elevator car. The detector is secured to the Long Bracket by using the M3.5 nuts, bolts and washers provided in the fixing kit.

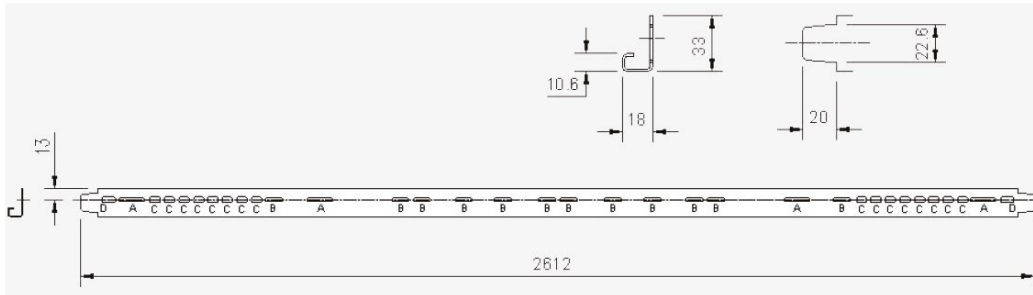

Mounting Profiles

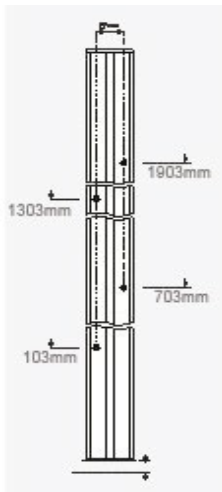

740 Mounting

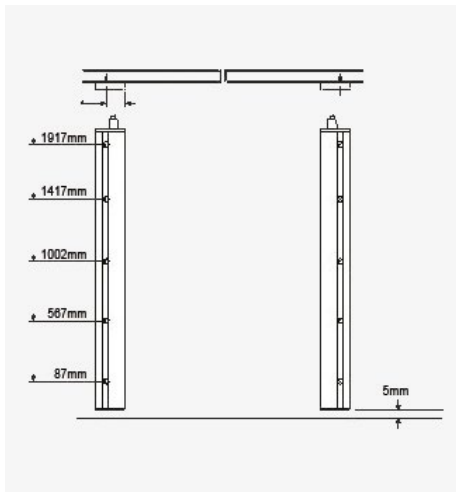

743 Mounting

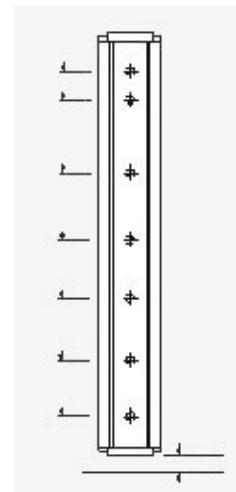

744 Mounting

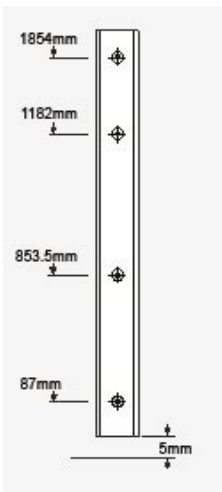

770 Mounting

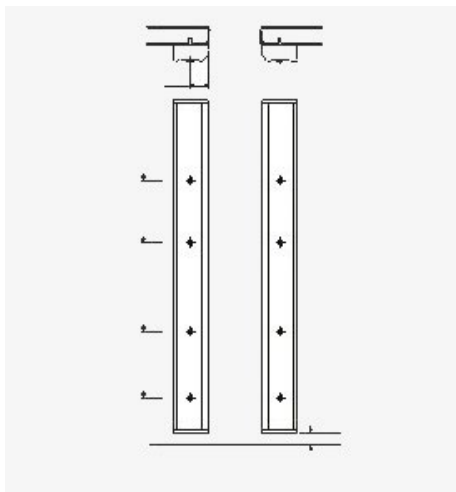

771 Mounting

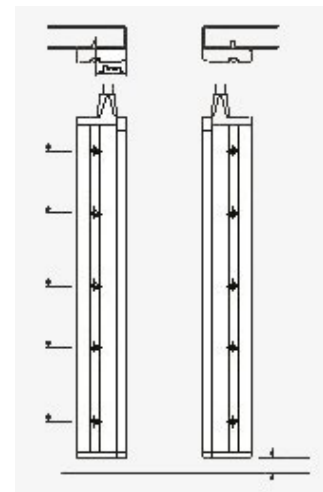

774 Mounting