



# AAU Analogue Lift Emergency Telephone



PSTN autodialler for reliable, hands-free and 2-way emergency communication



Full compliance with AS 1735.19-2019



Cloud monitoring via Avire Hub



Quick setup with keypad or remote access



Back up power with integrated battery



LP Bus Connectivity for system add-on

# AAU

## Analogue Lift Emergency Telephone



Avire's analogue audio unit (AAU) is an emergency lift telephone that connects entrapped passengers to rescue centres for assistance.

The PSTN auto-dialler enables reliable hands-free, 2-way emergency communication. Installation is quick and safety is assured with a system capable of remote diagnostics, monitoring and alerts.



### Comprehensive safety features with trusted reliability

The AAU is designed to ensure maximum uptime, easy call for assistance, and facilitation of clear communication with the rescue centre.

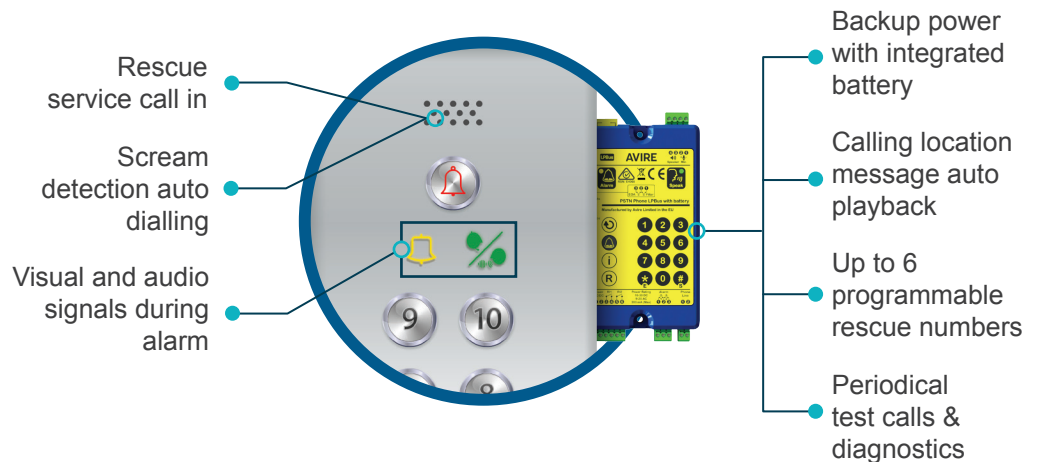



## Flexible installation options

AAU installs easily on the back of COP and is compatible with many existing alarm panel designs for seamless aesthetics.

- Share a PSTN line with up to 8 AAUs
- Compact, back of COP mounting
- Easy replacement of old telephones
- Output for 12 or 24 volt pictogram light (yellow/green)
- Optional external speaker & microphone

## Easy and quick to program

Get your lift into service faster with on-board keypad programming and remote setup capability. AAU's default settings are code compliant, and for quick installation only the following information needs to be programmed:

- Telephone numbers or PABX extension
- Location identification message
- Communication Protocol (Guided/Unguided Voice or P100)

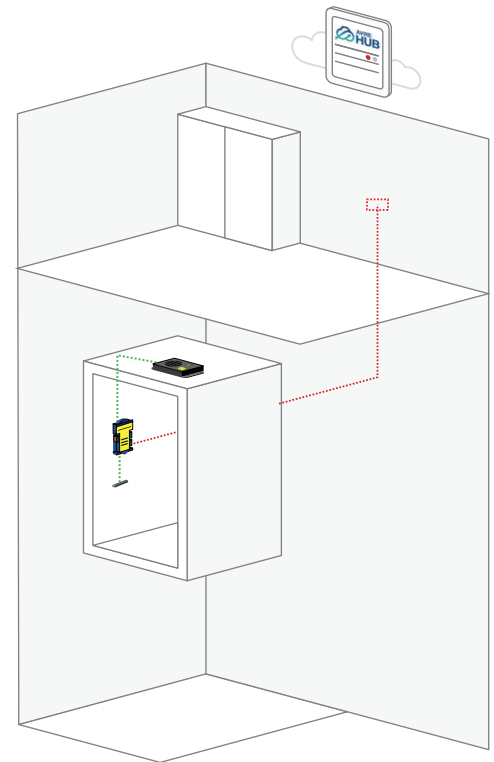

2-Wire Analogue Phone Line

LPBus

## Integrates with related lift safety appliances

Low Power Bus compatibility extends the power of AAU to complementary equipment for less wiring and smart interconnectivity



Surface alarm panel



Inductive loop



Triphony intercom unit

## Smart monitoring and full compliance

Avire's cloud management platform ensures operational compliance for your lift portfolio, by providing the following features:

- Status monitoring of all lifts
- Event logs
- Alerts via email (phone line, power and battery)
- Satisfies requirements for: EN81-28:2018 / AS1735.19-2019, EN 81-70:2018 and RCM (ACMA)



## Technical Specifications

Operating voltage	10-30V (DC), 9-20V (AC)
Standby current	39 mA
Operating current	53 mA (without external pictograms or accessories)
Dialling method	DTMF
Relay contact rating	3 V
Battery backup system	NiMH 3.6v 650 mAh
Battery operating time <sup>1</sup>	Up to 12 hours without pictograms / Up to 7 hours with pictograms
Speaker volume	User configurable
Speaker	8 ohms
Microphone	2.2 K ohms (freq. 100 - 16KHz)
Alarm button	Dry contacts
Operating temperature	0°C - 75°C
Dimensions	139mm x 80mm x 21mm

**Note 1:** Battery discharge testing conducted in 15 minute cycles; each cycle includes 10 minutes in standby and 5 minutes audio playback, simulating a conversation.

## Product Order Information

PART NO.	DESCRIPTION
AC-PNB10-120-A-0L-N00	AAU Analogue Lift Emergency Telephone

## Optional Accessories

PART NO.	PART NO.
AC-4CM10-620-F-20-000	4G Single Sim Digital Communication Platform - GSM/GPRS/RS-232
AC-4CM10-820-F-20-000	4G Dual Sim Digital Communication Platform - GSM/GPRS/RS-232
AC-KTB00-100-0-00-AAU	External Speaker/Mic Accessory
AC-AET08-100-0-0L-000	LPBus Triphony Unit (Top of Car Intercom)
AC-AES07-100-0-0L-EN1	LPBus Surface Mount COP Accessory
AC-ALB02-100-0-0L-000	LPBus Inductive Loop Accessory

## AVIRE FOR YOUR LIFT EMERGENCY TELEPHONE NEEDS



100,000+  
Installations  
Worldwide



Industrial-grade  
Performance &  
Durability



Local Sales &  
Technical  
Support



Global Expertise  
in Elevator  
Solutions

AAU-datasheet-V02-EN-AU\_25/01/24



**New Zealand Distributor**  
[WhiteSmithSolutions.com](http://WhiteSmithSolutions.com)

T: + 64 9 888 2239 E: [info@whitesmithsolutions.com](mailto:info@whitesmithsolutions.com)

As a result of our policy of continual improvement, the information in this document is subject to change without notice and it is intended only as general guidance on product performance and suitability. This information shall not form part of any contract.

# AVIRE