

PanaTouch MTP01

Product Datasheet



PanaTouch is a multimedia touch display and offers a brilliantly effective interactive experience for high-end installations.

The touchscreen on PanaTouch is highly responsive and combined with HD graphics this LCD display adds a sleek and modern finish for any lift or lobby.

Energy saving features including LED backlit technology and a screen power scheduler are the definition of thoughtful technology. PanaTouch has the capability to also deliver audio floor alerts, messages and gongs. It is also possible to use remote access to monitor and configure content.

The PanaTouch is not limited to elevators and can be used in a variety of settings such as lobbies, hallways and entrance foyers.

Key Features

- + Customisable layout
- + Vandalproof Touch Glass
- + Energy saving and eco-friendly
- + Projected capacitive (PCAP) touchscreen for high reliability
- + Landscape and portrait
- + Video live-streaming or recorded
- + Floor-level synchronised tenant content
- + Configurable via USB and LAN networks
- + Supports Mpeg 1/2/4 video
- + Supports plug and play media link solutions
- + HD Playback
- + Low power consumption

Example Screen Layouts

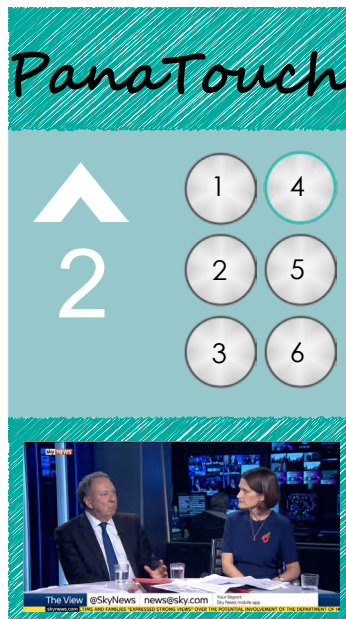
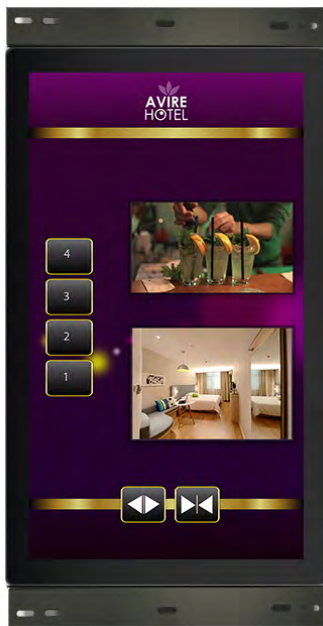

System Architecture

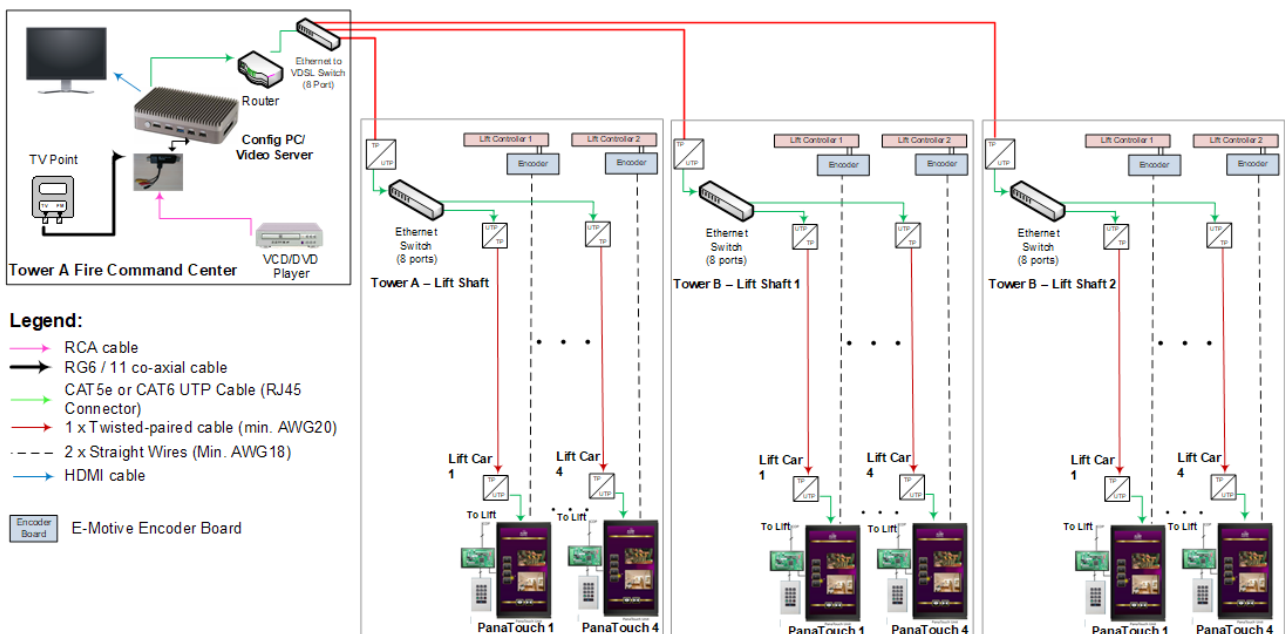

Note 1: The maximum length of the LAN cable (point-to-point inclusive of patch cable) is about 90m-100m. If length information is unclear, it is recommended a repeater or switch is installed. E-Motive supports Media-link solutions to extend the network beyond this.

Technical Specification

SCREEN SIZE	10.1	15.6	19.5	21.5
DISPLAY				
LCD Display Type	TFT	TFT	TFT	TFT
Colour Depth	True Colour (24-bit)	True Colour (24-bit)	True Colour (24-bit)	True Colour (24-bit)
Resolution ¹	1280 x 800	1366 x 768	1920 x 1080	1920 x 1080
Aspect Ratio	16:10	16:9	16:9	16:9
Viewing Area (W x H) (mm) ¹	217 x 136	344 x 194	437 x 241	478 x 269
Horizontal Viewing Angle (°) ¹	+85/-85	+80/-80	+89/-89	+89/-89
Vertical Viewing Angle (°) ^{1,3}	+85/-85	+80/-80	+89/-89	+89/-89
Luminance ¹ (cd/m ²)	315	270	225	300
Contrast Ratio ¹	800:1	500:1	3000:1	1000:1
ELECTRICAL & ENVIRONMENTAL				
Operating Voltage (VDC)	12	12	12	12
Typical Current Consumption (A) ⁸	1.08 (CPU) 0.83 (Aux Screen ⁵)	1.08 (CPU) 1.25 (Aux Screen ⁵)	1.08 (CPU) 1.47 (Aux Screen ⁵)	1.08 (CPU) 2.08 (Aux Screen ⁵)
Typical Power Consumption (W) ⁵	13 (CPU) 10 (Aux Screen ⁵)	13 (CPU) 15 (Aux Screen ⁵)	13 (CPU) 17.6 (Aux Screen ⁵)	13 (CPU) 25 (Aux Screen ⁵)
MECHANICAL				
Overall Dimensions ¹ (W x H x D mm)	190 x 315 x 41 (Aux Screen)	242 x 470 x 44 (Aux Screen)	290 x 558 x 46 (Aux Screen)	316 x 595 x 46 (Aux Screen)
COMMUNICATION & I/O INTERFACES				
Lift Interface ^{4,7}	E-Motive 4 wire Serial, 16-bit discrete Parallel	E-Motive 4 wire Serial, 16-bit discrete Parallel	E-Motive 4 wire Serial, 16-bit discrete Parallel	E-Motive 4 wire Serial, 16-bit discrete Parallel
PC Interface ⁶	LAN, Wireless ⁶	LAN, Wireless ⁶	LAN, Wireless ⁶	LAN, Wireless ⁶
Touch Interface	USB	USB	USB	USB

1. Specifications subject to change

2. Specifications of the auxillary screen

3. Special attention will be required to present best viewing angle

4. Communication between the lift controller and the display is controlled using an E-Motive encoder board, which is sold separately

5. The CPU is a low voltage device operating at 12VDC through a separated AC/DC switching power supply (IEC60950-1 compliance).

The auxillary screen operates at 12VDC and uses a separated AC/DC switching power supply (IEC60950-1 compliance). Each PSU will require an individual AC point.

6. Wireless communication requires a USB WiFi adaptor

7. If required, a separate E-Motive video server needs to be purchased

8. Typical power consumption varies accoring to content. Reduction in consumption can be achieved using a power save mode

Ordering Information

Part No.	Product Description
MTP01-101-4-13-920	10.1" PanaTouch
MTP01-156-3-13-920	15.6" PanaTouch
MTP01-195-3-13-920	19.5" PanaTouch
MTP01-215-3-13-920	21.5" PanaTouch

Accessories Available

133-C-1-0229	USB Extension Cable, 5m
147-2-0-0041	Ethernet Router
147-2-0-0039	Ethernet Switch, 8-Port
147-2-1-0039	Ethernet Switch, 16-Port
147-1-0-0042	Ethernet/VDSL Converter
147-1-0-0038	Ethernet/Fibre Optics Converter

Accessories Available cont.

VSERVER-MINI	Video Server Mini
VSERVER-MAX-900	Video Server Max,
VSERVER-MAX-901	Video Server Max, HDMI
SOFTWARE-CD	PanaTouch Software



AVIRE

E-Motive is a brand of Avire

Singapore **T:** +65 6776 4111
 Singapore: **E:** sales.sg@avire-global.com
W: www.avire-global.com

UK **T:** +441628 540100
 UK: **E:** sales.uk@avire-global.com
W: www.avire-global.com

USA **T:** +1 800 527 9156
 USA **E:** sales.us@avire-global.com
W: www.avire-global.com

